

# OWNER'S MANUAL



# SHOPSMITH

Mark 5

TMG-3469A-84(0)-P-7B\*

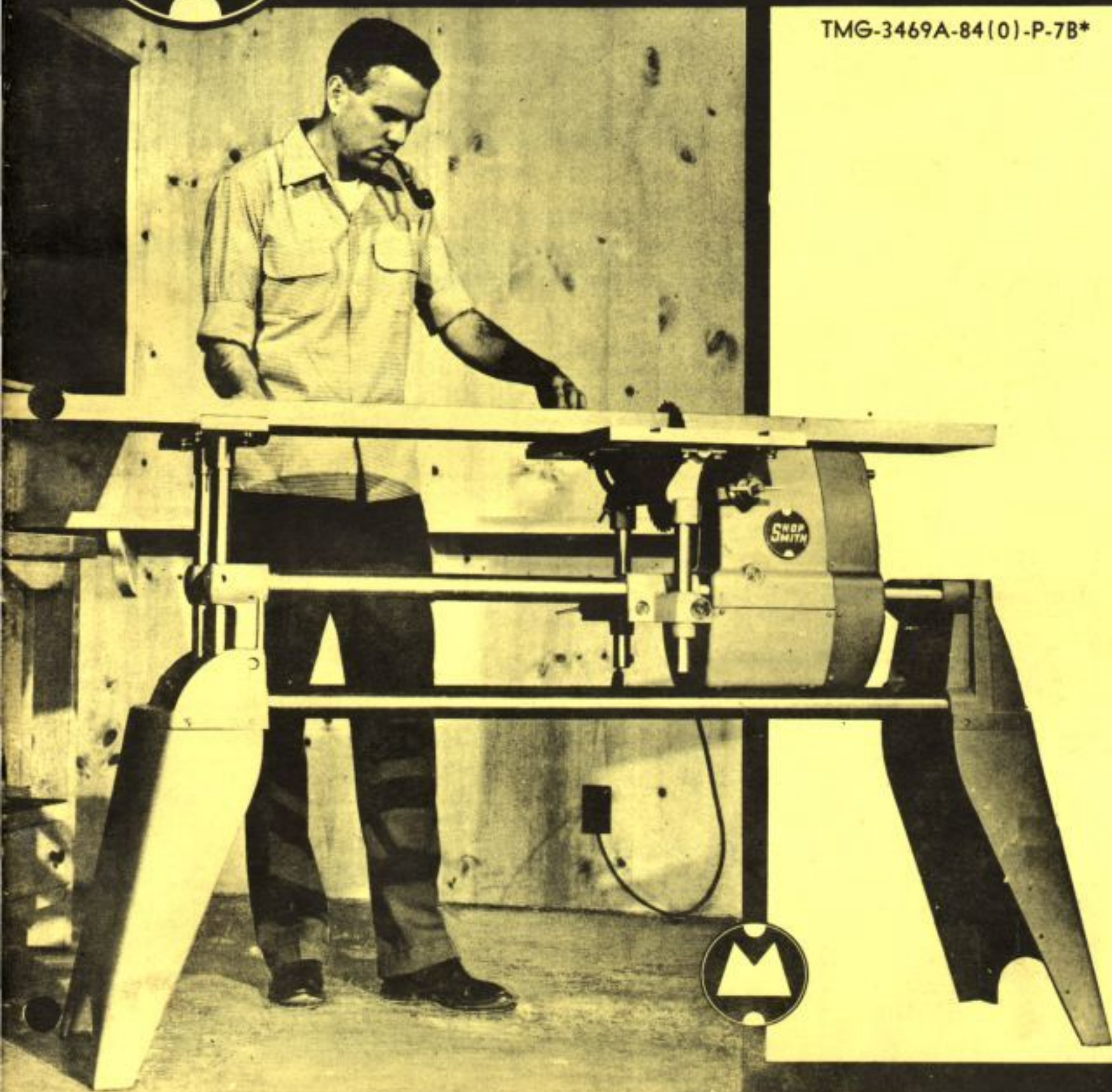

Here's why you can be proud of your new

# SHOPSMITH

**MARK 5**

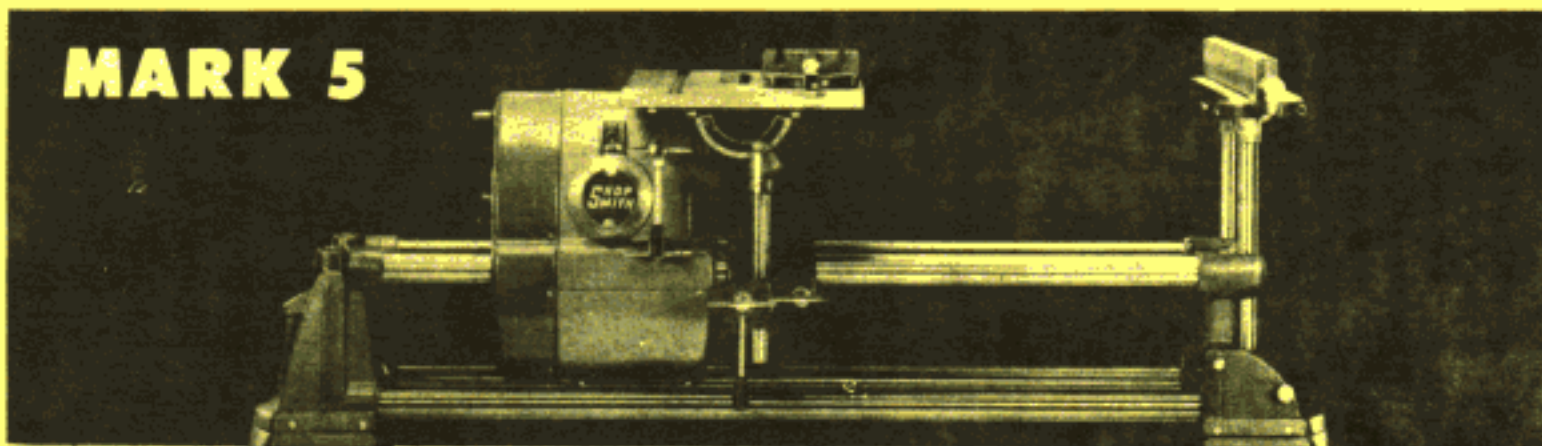

it sets standards never before achieved in the power tool field  
it's the one tool specifically designed with **you** in mind

## AS A COMPLETE POWER WORKSHOP IT GIVES YOU

### the best SAW available

with extreme accuracy for fine, close tolerance craftsmanship—with power and ruggedness for rough and tough construction—it plows through tough-grained Fir, whips cleanly and smoothly through soft Pine—it handles all jobs easily!



SEE PAGE 7

### the best DRILL PRESS available

actually, the only drill press specifically designed for woodworking—large table, locking miter gauge and self-squaring fence all contribute to more accurate, more convenient drilling—a capable woodworking drill press that handles tough metal drilling too!



SEE PAGE 13

### the best LATHE available

with exclusive, twin tube carriage to keep tool rest parallel to work at all times—with eccentric, cup center mount for accurate and mechanical off-set taper turning—with variable speed to give you correct *rpm* for small jobs and big ones too!

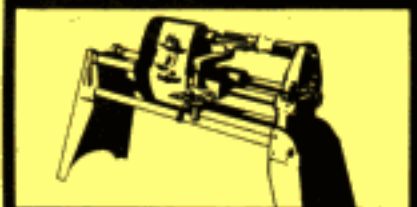

SEE PAGE 19

### the best DISC SANDER available

with revolutionary micro-quill feed for accuracy impossible to get any other way—with oversize 12" disc; a full 113 square inches of sanding area—with ready-made jigs through utilization of miter gauge and fence—the only disc sander with a big 14" x 18 1/2" table!

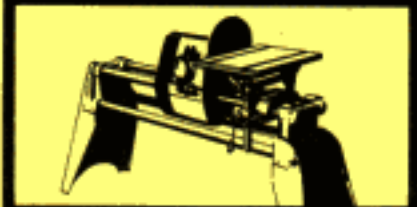

SEE PAGE 22

### the best HORIZONTAL DRILL available

actually, the only horizontal drill press available to homecraftsmen short of tremendous production machines—now you can enjoy the modern method of drilling for dowel joints—many jobs, normally done on a vertical drill press, you will soon be doing better and faster on the exclusive SHOPSMITH horizontal drill!



SEE PAGE 17



Your new SHOPSMITH Mark 5 results from years of intensive study beyond the success of the first SHOPSMITH. It sums up the experience of nearly 200,000 SHOPSMITH owners and includes features of safety and operational convenience long awaited by millions of home owners, amateur craftsmen and expert woodworkers.

Whether you are a do-it-yourself newcomer or an expert craftsman, of course you will want to study your new SHOPSMITH Mark 5 with this manual in your hand. Only as you become familiar with SHOPSMITH Mark 5 as a completely new concept will you be fully aware of the many new and exclusive features that will afford you a lifetime of home workshop pleasure and utility.



### A FEW OUTSTANDING FEATURES OF YOUR NEW SHOPSMITH MARK 5



#### SPEEDIAL

gives you the correct speed for any woodworking operation, and its as easy as dialing a phone—no belts to change—eliminates limitations leading to unsafe or inefficient speeds



#### EXTENSION TABLE

gives SHOPSMITH greatest blade to fence capacity of any saw—permits handling today's materials (plywood, hardboard, etc.) with ease—designed also for use as auxiliary table for upper auxiliary spindle

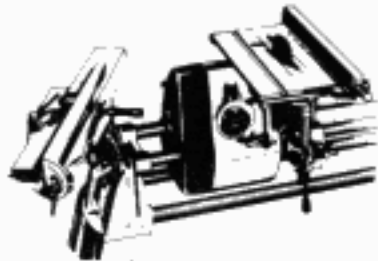

#### POWER-MOUNT

permits twin-tube mounting of major accessories in seconds — special flexible coupling power transmission from powerful  $\frac{3}{4}$  hp motor in headstock



#### RUST-PROOFING

no maintenance problems with SHOPSMITH—hard-chrome plating, hammer tone finish, lacquer coatings, all combine to keep SHOPSMITH looking new, always

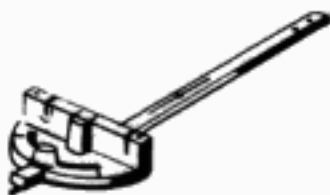

#### MITER GAUGE BAR LOCK

special taper lock set screw in miter gauge bar permits locking miter gauge in either table slot —affords excellent use of miter gauge as jig, stop.



#### DEPTH GAUGE

dial depth control on  $4\frac{1}{4}$ " quill feed is simple and accurate — simply turn dial to the setting required and lock — no inconvenient stop nuts or rods



#### ECCENTRIC CUP CENTER MOUNT

accurate and mechanical off-set taper turning merely by revolving cup center mount and clamping chisel to parallel moving tool rest.

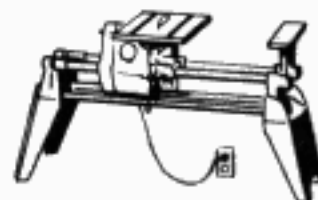

#### PLUG-IN INSTALLATION

no elaborate assembly work—even if you have SHOPSMITH Mark 5 delivered in the crate, it takes but a few minutes and a screw driver to have it ready to plug in

## Helpful Suggestions

The revolutionary features incorporated in SHOPSMITH M5 are so unlike ordinary tools you must learn to use them correctly for maximum utility, safety and satisfaction. **Remember these basic rules and OBEY THEM!**

1. The auxiliary (POWER MOUNT) spindle of SHOPSMITH M5 rotates in a direction opposite to the standard rotation of the main spindle. This means that you should NEVER mount attachments on the auxiliary spindle unless they are designed to operate safely and hold securely in that direction of rotation. Observe the following rules carefully:
  - a. NEVER use the Flexible Shaft (#12 326) on the auxiliary spindle as attachments can loosen and the shaft may be damaged.
  - b. NEVER use an arbor other than the special SHOPSMITH  $\frac{1}{2}$ " and  $\frac{3}{8}$ " arbors (#22 030 and #22 031) for mounting attachments on the auxiliary spindle. These arbors include a tongued washer which seats
2. NEVER leave the POWER MOUNT coupling (#22 001) attached to a power driven spindle when not connected to a POWER MOUNT accessory—Jointer, Jigsaw, etc.
3. ALWAYS turn SPEEDIAL to "slow" before changing from one operation to another unless the next operation requires a HIGHER speed. Thus, you will avoid the possibility of inadvertently operating an attachment at an unsafe speed.
4. When operating one tool on POWER MOUNT and another on the main spindle, never exceed maximum safe speed for either tool.
5. Read this OWNER'S MANUAL carefully before operating your new SHOPSMITH M5. Obey all rules for maximum safety, utility and satisfaction.

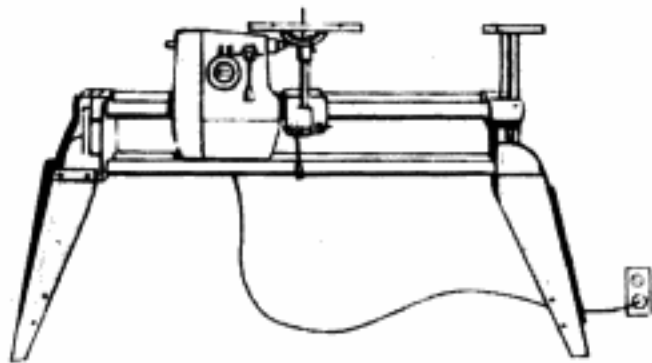

### Plug-In Installation

SHOPSMITH M5 is normally delivered set up and ready to go. All you have to do is plug it in. If for some special reason you have SHOPSMITH M5 delivered in the crate, you can quickly set it up with a screw driver.

After uncrating, support SHOPSMITH horizontally across two kitchen chairs, saw horses or anything that will hold it about two feet off the floor. The top end of the interchangeable bench ends is joggled to fit snugly inside the base castings. Insert the five countersunk screws ( $\frac{1}{4}$ " x  $\frac{5}{8}$ ") through mating holes in casting and bench end. Thread washers and nuts on each of the screws and finger-tighten. Then, holding the nut with a wrench or pliers and turning the head with a screw driver, lock the screws in place.

Notice the pre-punched holes in each bench end. The bottom holes (two on each flange) are for mounting retractable casters, an extremely useful accessory which makes SHOPSMITH a mobile unit easily "castered" anywhere in or outside the home or shop. The upper holes (two on each flange) are there if you want to add a wood shelf to the unit.

Before starting the motor check your line fuses. Because a powerful motor draws an initial starting load greater than required during continuous running, it is good practice to equip the circuit supplying current to the machine with a *delayed action fuse*. This is the same type fuse called for on circuits for washing machines, driers, and other household appliances.

## INDEX

	PAGE
General Nomenclature . . . . .	5
SPEEDIAL . . . . .	6
Checking for Accuracy . . . . .	6
Table Saw . . . . .	7
Accessories . . . . .	10
Drill Press . . . . .	13
Accessories . . . . .	15
Horizontal Drill Press . . . . .	17
Lathe . . . . .	19
Accessories . . . . .	21
Disc Sander . . . . .	22
Accessories . . . . .	23
Adjustments . . . . .	24
Major Accessories . . . . .	24
General Accessories . . . . .	25
Exploded Views . . . . .	26
Parts List . . . . .	26
Accessory Numbers . . . . .	30
A Safe Shop . . . . .	31
Maintenance and Lubrication . . . . .	31
Operational Speeds . . . . .	32

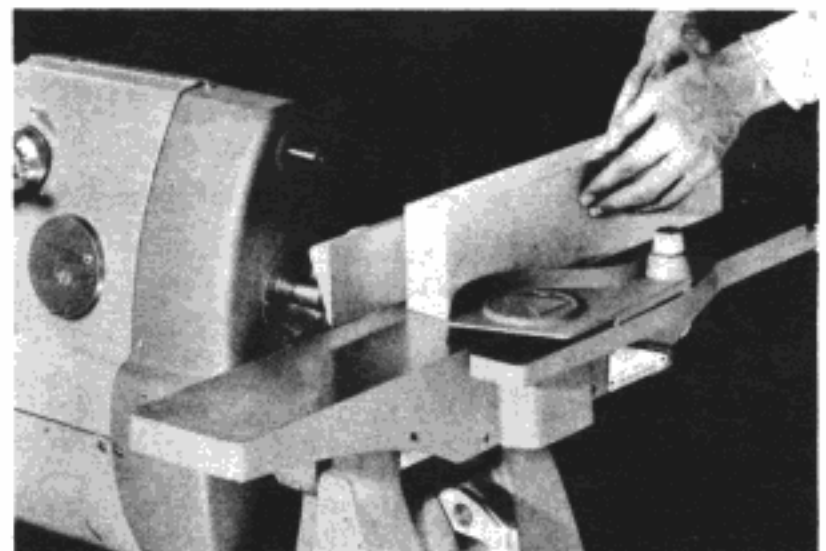

Jointer on POWER MOUNT

## SHOPSMITH Mark 5 Nomenclature . . .

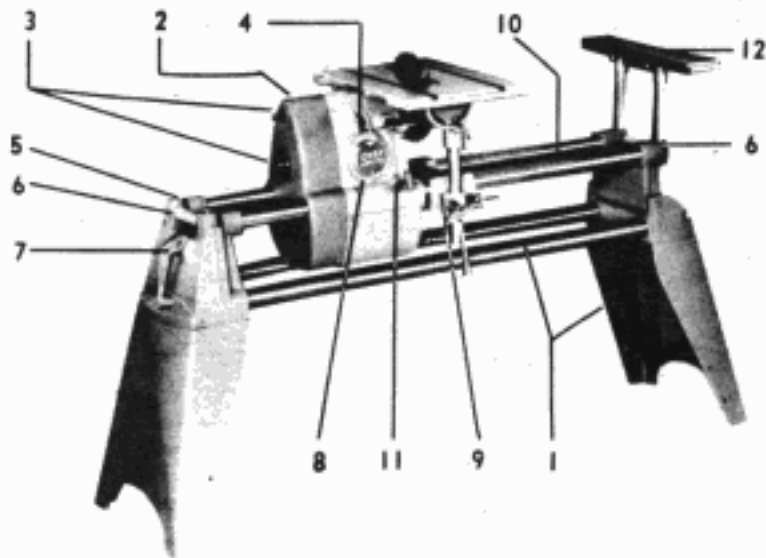

Fig. 1 SHOPSMITH M5

1. **Bench ends and tubes** . . . Integral part of machine. Provide rigid base. Eliminate need to buy or build wood structure.
2. **Headstock** . . . Motor and all rotating parts totally enclosed in solid, pressure cast, aircraft quality aluminum alloy.

3. **Auxiliary spindles** . . . Extra safety-flat spindles for dual mounting of complementary tools.
4. **On-off switch** . . . Set between guard wings for protection against accidentally turning on machine. Can be knocked OFF but not ON.
5. **POWER MOUNT** . . . For mounting extension table or major accessories such as Jointer or Jigsaw.
6. **Hand grip locks** . . . One at each end—positive lock for extension table, tailstock or accessories.
7. **Headrest lock** . . . Secures SHOPSMITH in horizontal position.
8. **SPEEDIAL** . . . Makes available the correct speed for any operation merely by turning a dial.
9. **Carriage** . . . Supports table or lathe tool rest. Slides on tubular ways.
10. **Tubular ways** . . . Centerless ground twin tubes provide extreme rigidity and accuracy. Anti-corrosion hard-chrome plated.
11. **Headstock lock** . . . Locks headstock in any position along tubular ways.
12. **Extension table** . . . Mounts at either end of machine—affords exceptional capacity for sawing drilling, sanding, etc. Also usable as auxiliary table for upper auxiliary spindle.

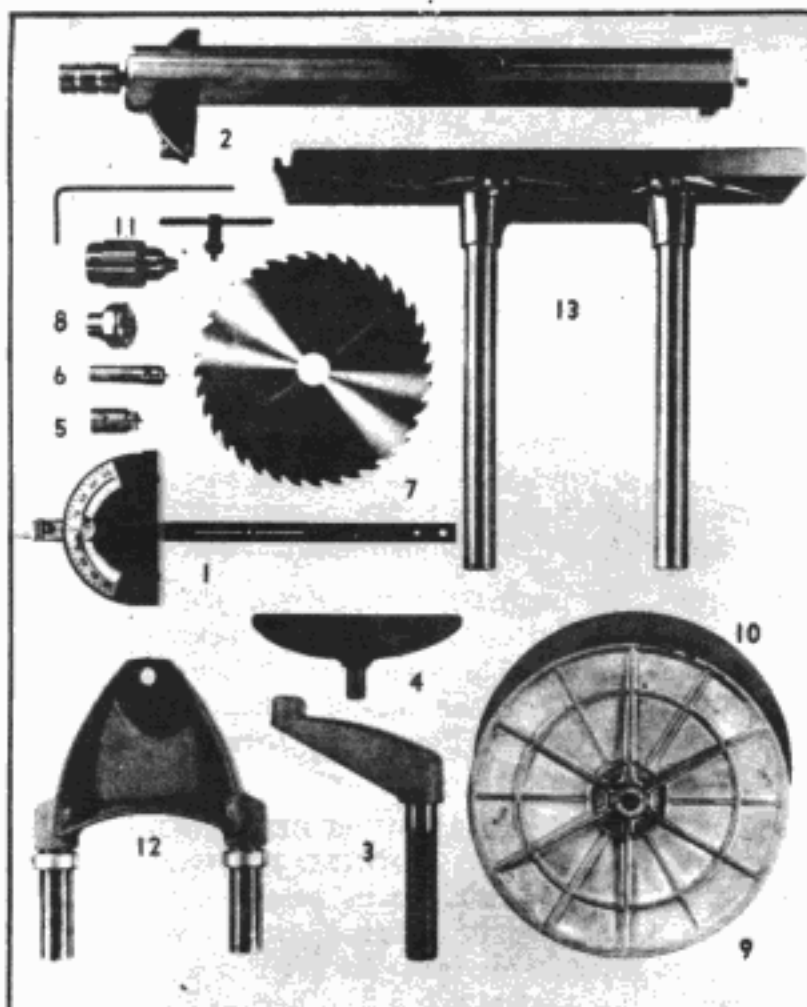

Fig. 2 SHOPSMITH M5 standard attachments

1. **Miter gauge** . . . Used for crosscutting and mitering operations on table saw. Also used as stop, guide and jig for many other operations.
2. **Rip fence** . . . Used for ripping cuts on table saw. Also used as guide, stop, support and jig for many other operations.
3. **Tool rest arm** . . . Used in front hole of table carriage to support lathe tool rest.
4. **Lathe tool rest** . . . Guide and support for lathe turning tools.
5. **Drive center** . . . For spindle turning. Attaches to main spindle.
6. **Cup center** . . . For tailstock end of spindle turning. Seats in tapered hole in eccentric cup mount.
7. **9" saw blade** . . . SHOPSMITH M5 all-purpose saw blade; used for both crosscutting and ripping.
8. **1 1/4" saw blade arbor** . . . Special arbor for 9" blades; attaches to main spindle and positions blade to minimize run-out and wobble.
9. **Sanding disc** . . . 12" sanding disc attaches to spindle—balanced for vibration-free operation.
10. **Sandpaper** . . . 12" sandpaper sheet attaches to disc with adhesive provided.
11. **Chuck and key, Allen wrench** . . . Jacobs chuck for tools with 5/64"-1/2" diameter shanks. Allen wrench, SHOPSMITH M5 "Tool Kit."
12. **Tailstock** . . . Holds eccentric cup center mount.
13. **Extension table** . . . Mounts on either end of machine.

## SPEEDIAL

SHOPSMITH M5 SPEEDIAL (Fig. 3) makes speed selection as easy as dialing a phone. Settings for most common operations are engraved on the dial. For more detailed operational speed information refer to the speed chart on page 32.

Turning the dial *clockwise* (Figs. 4 and 5), increases speed; turning *counter-clockwise* decreases speed. NEVER ATTEMPT TO CHANGE SPEEDS WHEN THE MOTOR IS TURNED OFF. MAKE IT A HABIT TO TURN SPEEDIAL TO "SLOW" BEFORE SHUTTING OFF MOTOR FOR POSITION OR ACCESSORY CHANGE UNLESS THE NEXT OPERATION REQUIRES A HIGHER SPEED. After the accessory is attached to the spindle, switch on the motor and turn SPEEDIAL to the rpm required. For example:—

If you have been using the saw and wish to change to the disc sander, turn SPEEDIAL to "sand" before turning off the motor and removing the saw blade. Then replace the saw blade with the disc sander.

It is a good idea to get the feel of the SPEEDIAL before locking any attachments on the spindle. Merely plug in the machine and turn on the switch. Turn the dial slowly clockwise and you will sense the increase in speed. It is not good practice to force the dial—turn it slowly, especially when decreasing speed.

**NOTE: SHOPSMITH M5** provides an infinite speed range between "slow" and "fast." Some variation may be expected due to belt wear and "break-in" of parts.



Fig. 3 SHOPSMITH M5 SPEEDIAL

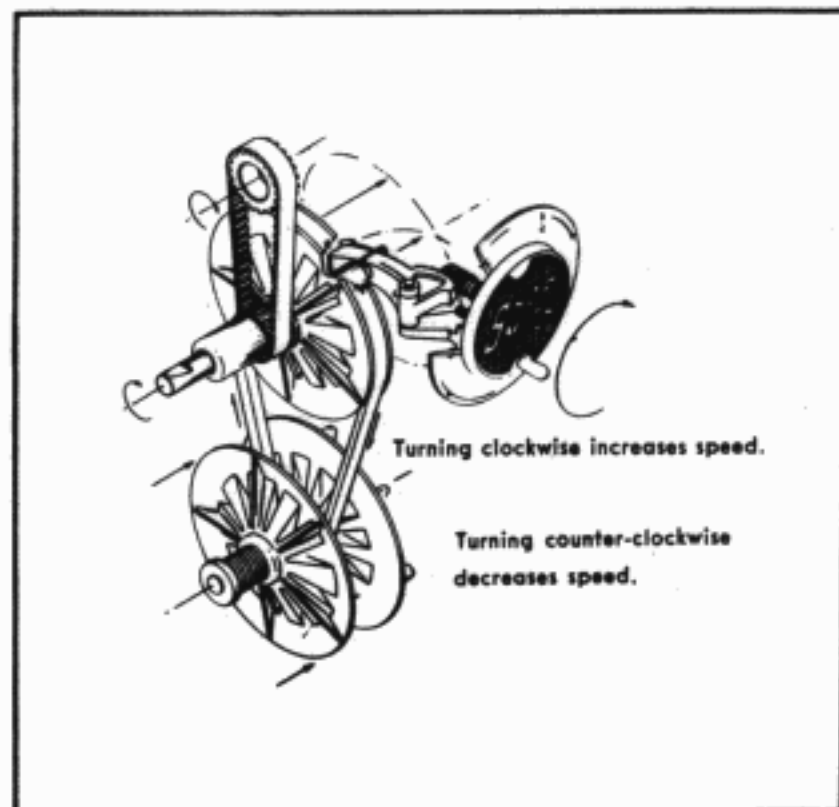

Fig. 4 SHOPSMITH M5 variable speed changer mechanism

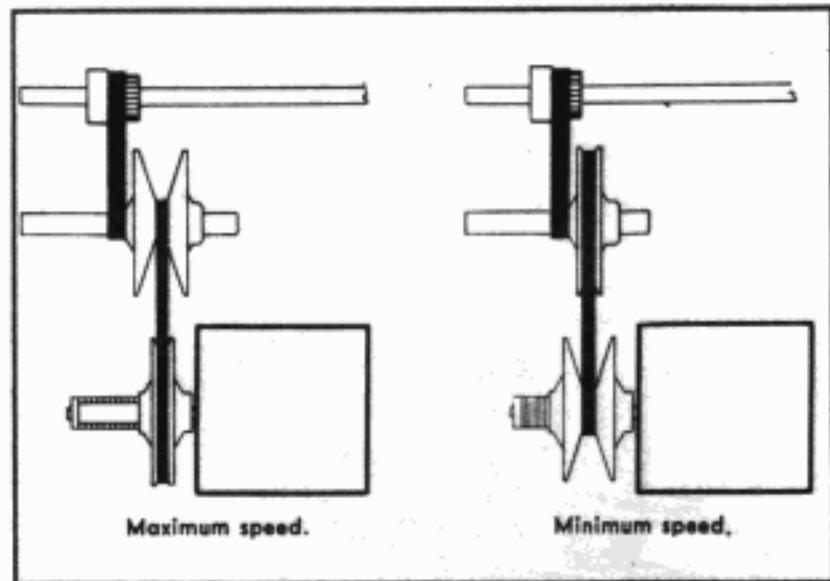

Fig. 5 Pulleys at "fast" and "slow" settings

## Checking for Accuracy

A good craftsman makes periodic checks of his machine to be sure that related parts are in correct alignment. Here is what to look for and good methods for checking.

1.... AT "O" TRUNNION SETTING, THE TABLE MUST BE SQUARE TO THE SAW BLADE. This is checked with the table as low as possible and locked in position about  $\frac{1}{8}$ " away from the saw blade (Fig. 6). Be sure the square used for checking rests flat against the blade and that it seats between teeth. If the angle between blade and table is not exactly 90 degrees, adjustment is required. (See section on Adjustments.)

2.... TABLE SLOTS MUST BE PARALLEL TO SAW BLADE. Check by setting table as low as possible in normal sawing position. Place the miter gauge in either slot and clamp the Allen wrench to its face so that it extends just enough to touch one tooth of the blade set in the direction of the miter gauge (Fig. 7). Mark the tooth with a pencil. The miter gauge stop rod, if available, may be used in place of the Allen wrench. Rotate the saw blade backwards by hand until that same tooth is at the rear of the insert slot. Move the miter gauge ahead and check to see if the Allen wrench just barely touches that same tooth. If it does not, adjustment is required.

3.... THE MITER GAUGE, WHEN SET AT 90 DEGREES, MUST BE AT RIGHT ANGLES TO THE TABLE SLOTS. To check, set miter gauge in either slot and use a square as shown in Fig. 8. Be sure that one arm of the square is held firmly against the face of the miter gauge and the other is flush against the side of the second table slot. If the angle between miter gauge and slot is not exactly 90 degrees, adjustment is required.

4.... THE RIP FENCE, WHEN LOCKED, MUST BE PARALLEL TO THE TABLE SLOTS. Check by locking the rip fence on the table, positioned so that one side of the fence is flush with one side of either table slot (Fig. 9). If the rip fence is not exactly parallel to the slot, adjustment is required.

5.... THE EXTENSION TABLE MUST BE PARALLEL TO THE SAW TABLE AND ALIGNED WITH IT. Check by setting the extension table to the height of the saw table and butting them against each other. Place a straight edge across front edges (Fig. 10). If tables do not butt flush and if front edges are not in line, adjustment is required.

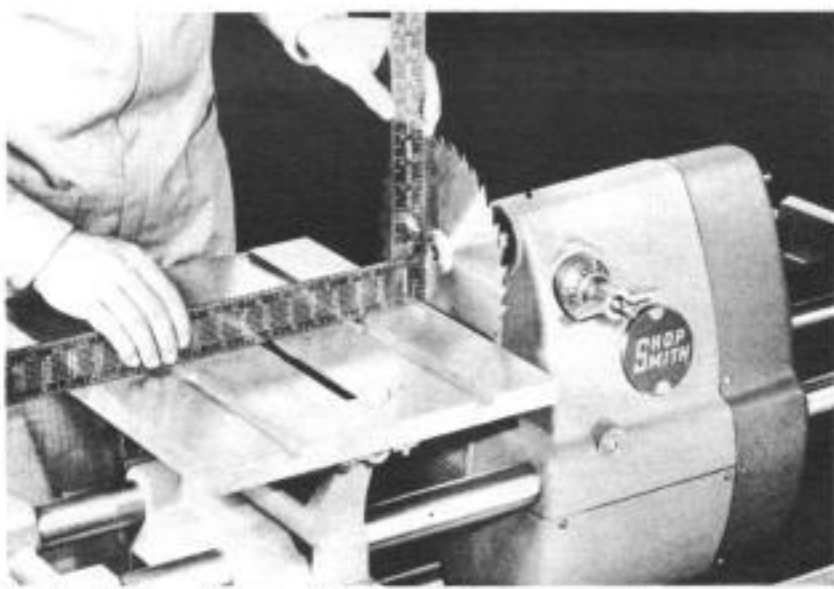

Fig. 6 Table must be exactly 90° to blade

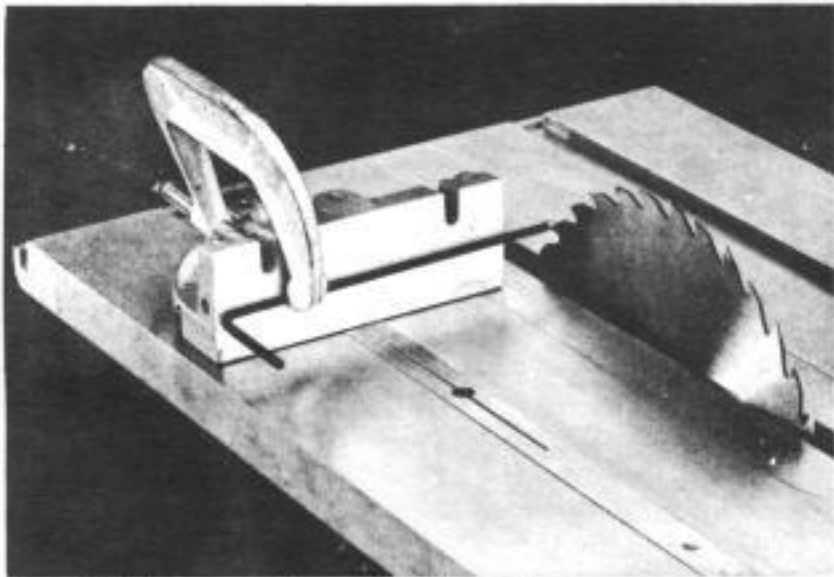

Fig. 7 Table slots must be parallel with saw blade

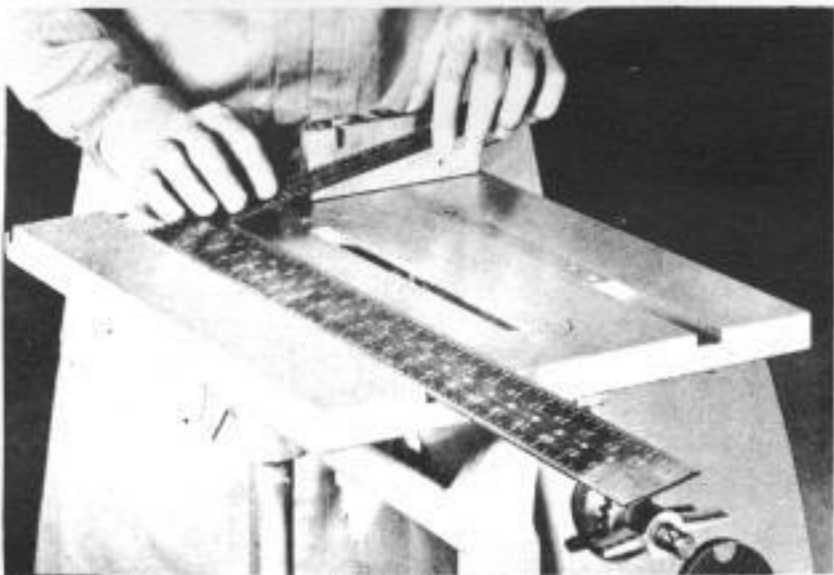

Fig. 8 Miter gauge must be 90° to table slots

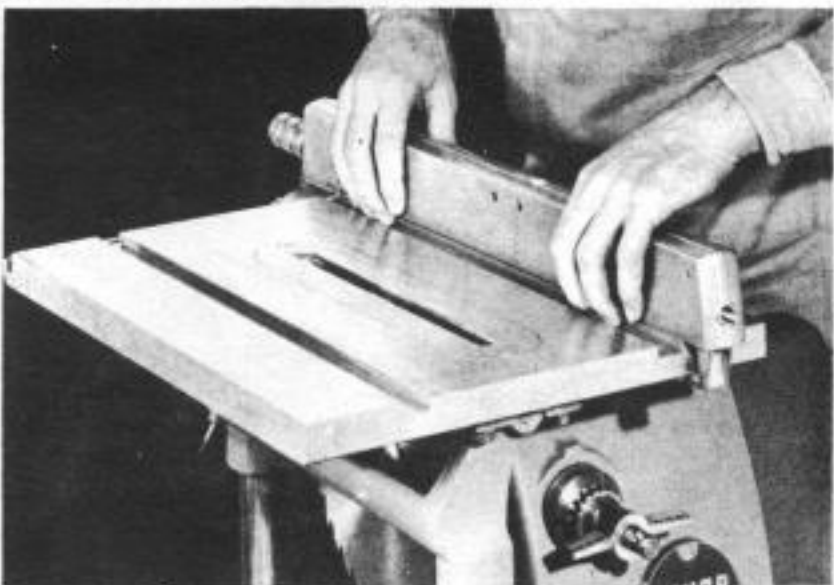

Fig. 9 Rip fence must be parallel with table slots

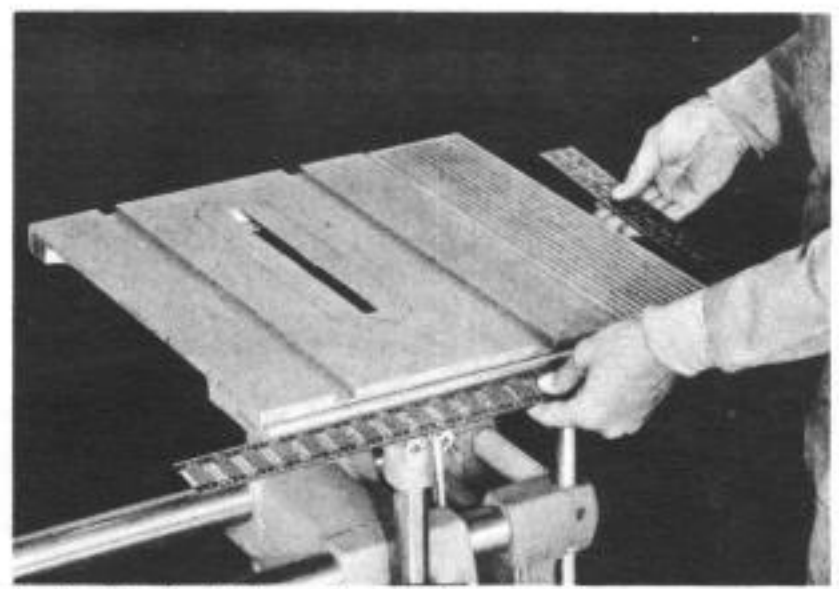

Fig. 10 Extension table must line up with saw table

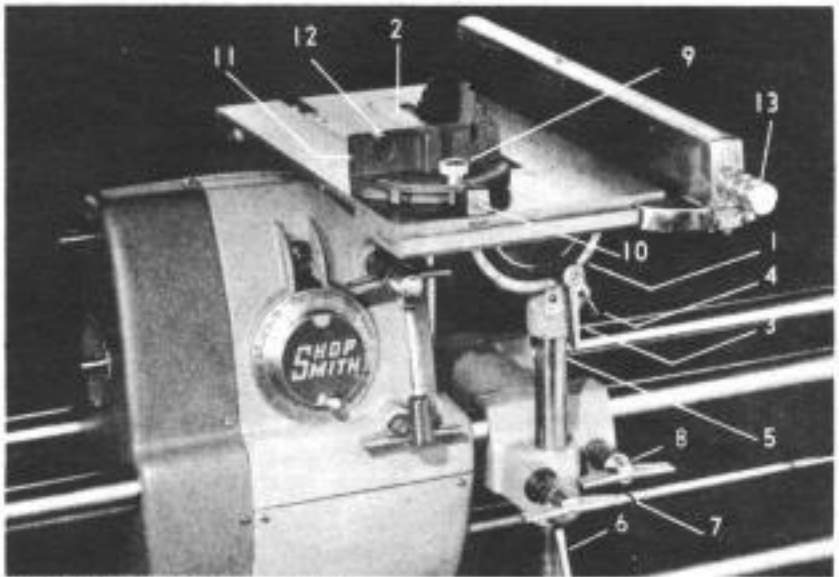

Fig. 11 SHOPSMITH M5 table saw

### The Table Saw

1. **Trunnion** . . . Guides table through tilt range—calibrated for angular settings.
2. **Insert** . . . Removable insert is coined and "bowed" for accurate, flush fit; integral projections prevent saw blade cutting insert.
3. **Table tilt lock** . . . Locks table at any angular setting.
4. **Trunnion plunger** . . . Pin against which auto-stop set screws bear at 0 to 45 degrees.
5. **Table tubes** . . . Rack cut for raising or lowering table.
6. **Table height lever** . . . Use to raise or lower table—lever is adjustable radially by unscrewing a few turns, repositioning and then locking.
7. **Table height lock** . . . Turning clockwise lock height setting obtained with height lever.
8. **Carriage lock** . . . Turning clockwise locks carriage in any position along tubes.
9. **Miter gauge knob** . . . Locks miter gauge settings.
10. **Miter gauge plunger** . . . Pin against which auto-stop set screws bear at 45, 90, and 45 degrees.
11. **Stop rod holes** . . . Permit mounting of miter gauge stop rods for duplicate cutting.
12. **Miter gauge extension slots** . . . For mounting miter gauge extensions.
13. **Rip fence lock handle** . . . Turning clockwise automatically squares fence to table and locks it front and rear.

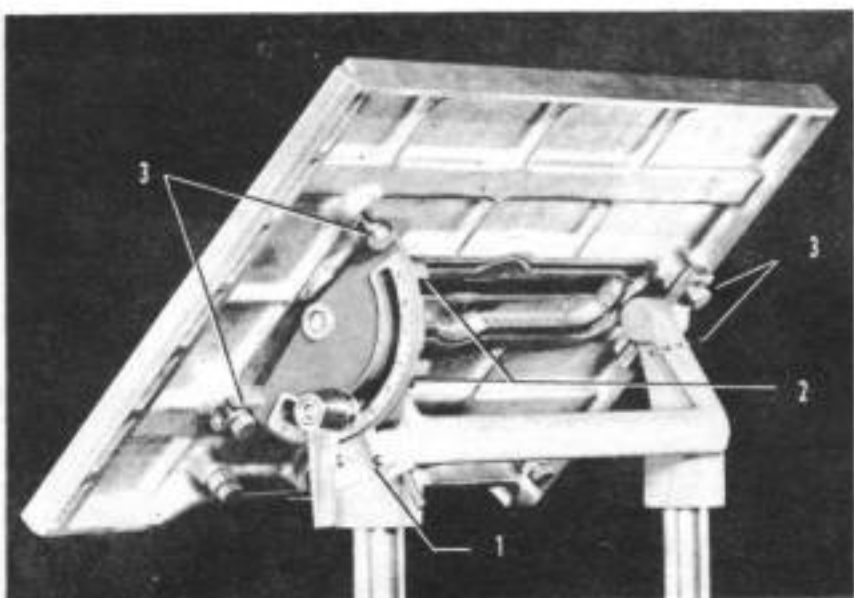

Fig. 12 Underside of SHOPS MITH M5 saw table

1. **Trunnion vernier plate** . . . Adjustable, stamped plate for tilting table to exact degree.
2. **Trunnion autostop set screws** . . . Adjustable Nylock screws afford automatic settings at most used angular settings.
3. **Cap screws** . . . Hold table to trunnion and rear bracket. Loosen for table alignment.

## How to Use the Table Saw

### Mounting the Saw Blade

The 9" saw blade mounts on the special 1 1/4" saw blade arbor. Remove the arbor nut by turning it clockwise (thread is left hand so nut will tend to tighten as saw turns). Hold the arbor with the flats pointing toward your left. Slip on the saw blade with the teeth pointing in your direction. Replace the nut and finger-tighten by turning counter-clockwise. Place the arbor on the spindle with the set screw positioned over the tapered flat and lock in place with the Allen wrench. Hold the arbor flats with one wrench and the arbor nut with the special wrench provided and tighten.

All spindle attachments should be positioned with the locking set screw seating firmly on the tapered flat. This safety feature is provided on upper spindles as a precaution against tools flying off even if set screws are not sufficiently tightened.

When it is necessary to remove the blade from the arbor loosen the arbor nut while the arbor is still mounted on the spindle—or—remove the arbor and grip the flats in the jaws of a vise. Actually it should not be necessary to remove a saw blade from its arbor except for sharpening. Arbors are economically priced so SHOPS MITH owners can have all their accessories pre-mounted on individual arbors ready for mounting on the spindle in seconds. Be sure to utilize this SHOPS MITH feature.

### Positioning Table

Rack the table to its highest point, lock, and slide carriage toward headstock until slotted screw on headstock side of carriage butts against headstock. Lower table and check to see if saw blade is centered in insert slot. If not, loosen hex nut which secures slotted screw, adjust screw until the saw blade is centered, then lock the nut. Many craftsmen adjust the screw to position the saw blade nearer the left side of the slot. This permits more leeway for SHOPS MITH's quill adjustment.

### Blade Projection

Avoid extremes in blade projection above work. 1/4" to 1/2", or exposure to deepest gullet of blade (except with hollow ground blades where exposure should be at least 3/4") is safe and efficient (Fig. 14).

When saw blade, dado or other cutting tools must be set to a definite height, use the depth-of-cut scale engraved on each side of the rip fence. Bring the fence

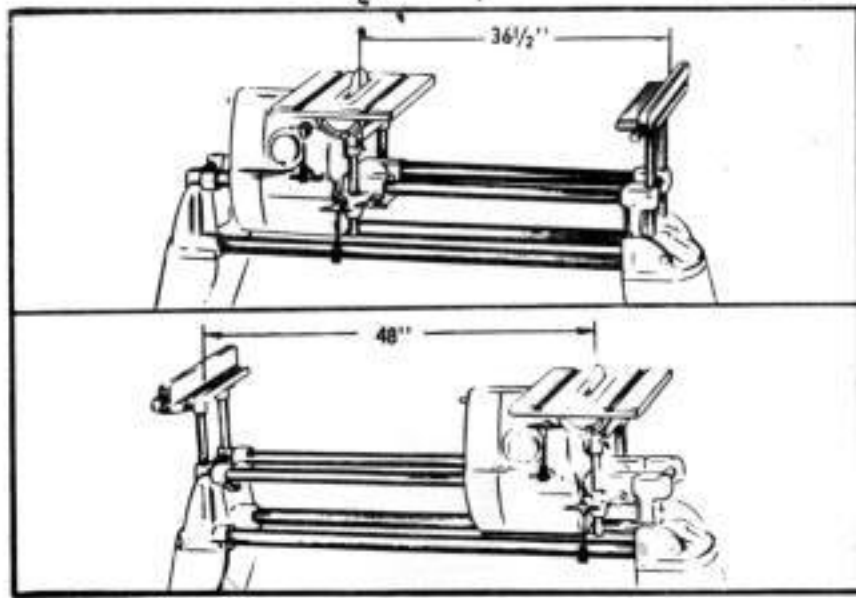

Fig. 13 SHOPS MITH M5 table saw capacities

Exposure to deepest gullet is safe and efficient except on Hollow Ground Blades . . . exposure should be 3/4" minimum.

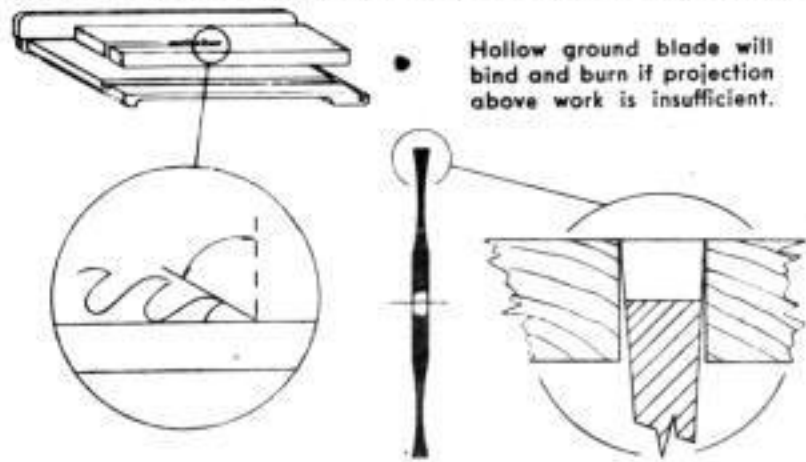

Fig. 14 Blade projection above work

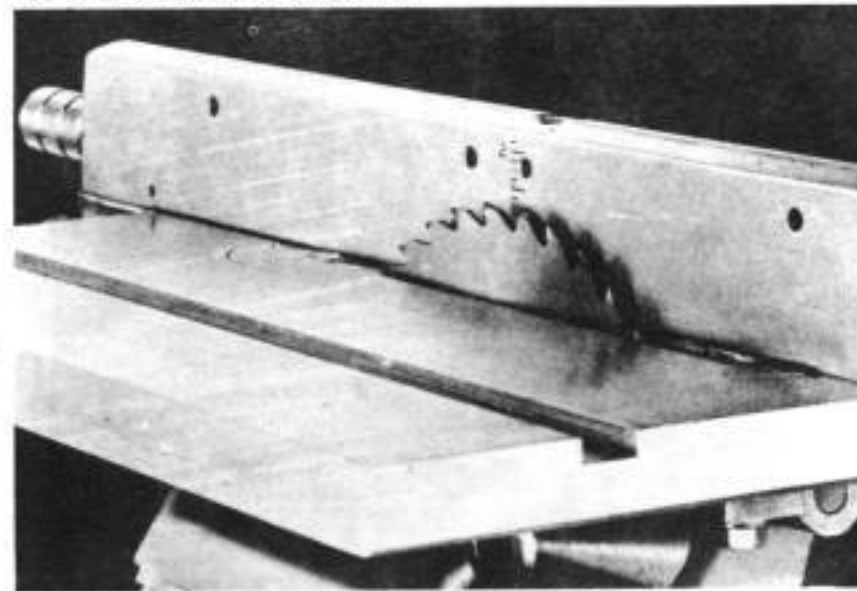

Fig. 15 Using rip fence scale to adjust blade height



Fig. 16 Using quill feed for blade to fence setting



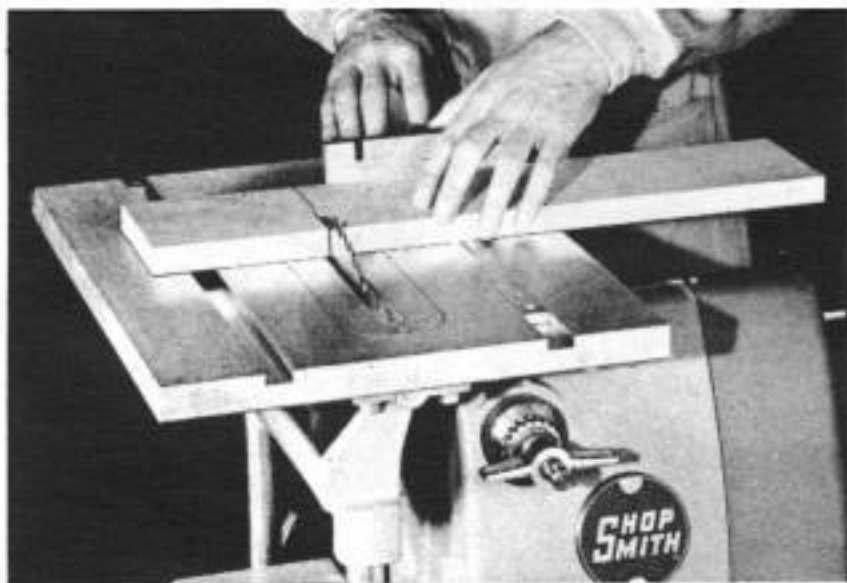

Fig. 17 Correct use of miter gauge when crosscutting

Miter gauge range on either side of blade

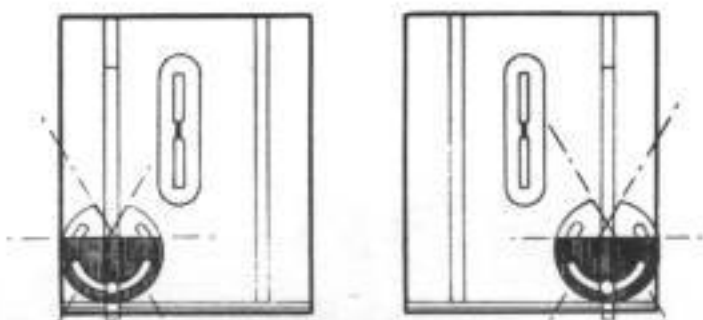

Fig. 18 Miter gauge range on either side of blade

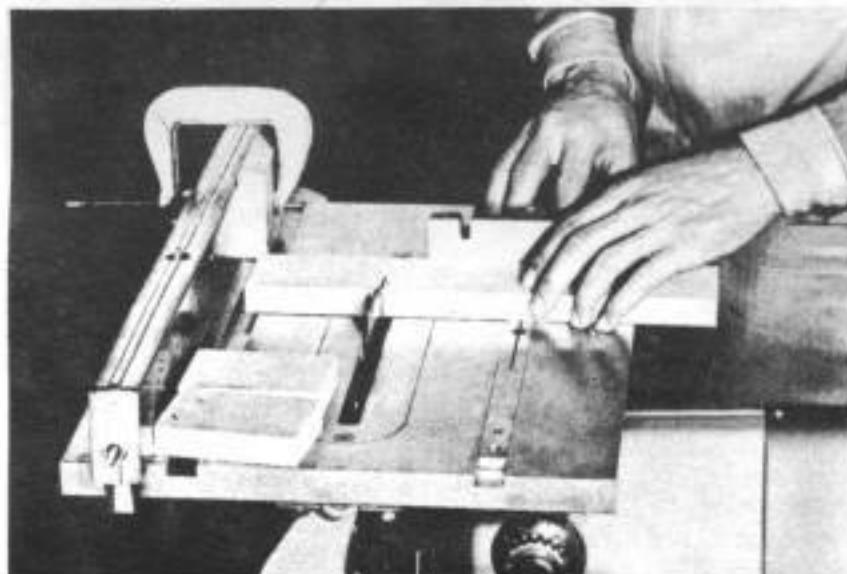

Fig. 19 Duplicate cutting—stop block clamped to fence



Fig. 20 Hook fingers over fence when ripping

close to the blade and lock in position. Raise or lower table until cutting tool height is correct (Fig. 15). This exclusive SHOPSMITH feature guarantees accurate depth of cut since it is not affected by blade sharpening, various blade sizes, etc.

### Blade to Fence Settings

SHOPSMITH's quill feed makes precise blade-to-fence settings easy. Set the rip fence manually to an approximate position within  $\frac{1}{8}$ " of the setting required. Lock the fence and make the final, critical adjustment by advancing the quill and locking it in position with the quill lock (Fig. 16).

### Crosscutting

The miter gauge, positioned in either of the table slots, holds the work square to the blade throughout the pass.

Hands should be placed on the miter gauge as shown (Fig. 17), body positioned out of the line of cut. Use the left hand to hold the work against the face of the miter gauge and down on the table, while the right hand feeds it forward. *Never force or rush the cut.* You will always get a smoother, better cut and a minimum of blade chatter with a slower pass since you are letting more teeth pass over a given area of the wood. When the wood is cut through, keep hands in same position and return work and miter gauge to the starting point. Never attempt to remove the cutoff until you have switched off the machine and the blade has stopped turning. This takes but a second and will avoid accidents.

### Miter Cuts

Miter cuts (Fig. 18) are made like crosscuts except that the miter gauge is adjusted to the angle required. A firm grip is needed to counteract "creep" which is the pulling action of the blade on the work as the cut is made. *As always, make the pass slowly,* hands holding the work firmly and positioned on the miter gauge well away from the saw blade.

SHOPSMITH's Miter Gauge Safety Grip is especially useful on cuts of this nature.

### Cutting Off Duplicate Lengths

Many beginners, needing short duplicate lengths, make the mistake of using the rip fence to gauge the length of the cutoff. This is a dangerous practice and *should never be attempted.* The cutoff can jam between blade and fence, and may be thrown back with considerable force.

Instead, clamp a stop block to the rip fence as shown in Fig. 19. This should be positioned forward of the saw blade. The work is butted against it and then advanced with the miter gauge to make the cut.

### Ripping

Rip cuts are accomplished by passing the work between the saw blade and rip fence. Hand and body positions depend a great deal on the length and width of the work. The general rule is—always stand out of the line of cut; *never use hands too close to the saw blade.*

Usually, the left hand holds the work down on the table and snug against the fence (Fig. 20). The right hand, with fingers hooked over the fence as shown, feeds the work forward. Always feed the work through so the overhang at the back of the table will tilt the board up where it is easily gripped with the right hand and lifted from the table.

Cuts which are narrower than 3 or 4 inches should never be pushed through by hand. Always use a push stick (Fig. 21). You may, if the work is long, start the cut by hand but the last six inches should be pushed through with the stick.

Push sticks are very easy to make (Fig. 22) and should be kept handy for use at all times.

### Bevel Ripping

Bevel rip cuts are accomplished by tilting the table to the angle needed, locking it in place and making the pass

as you would for a normal rip cut (Fig. 23). The fence is always situated on the *right* side of the blade which creates a convenient V-block arrangement to support the work.

Because the pivot center of the table is below the table top, the saw slot moves in an arc as the table is tilted. This necessitates advancing the saw blade so that it may be centered in the saw slot at the angle of tilt needed. This is done by simultaneously advancing the blade as the table is tilted. An alternate method is to tilt the table, raise it, and then advance the saw blade and lower the table over the blade.

To tilt to 45 degrees, pull plunger out and tilt table to maximum setting, then push in plunger and return table until 45 degree auto-stop set screw bears against pin. When returning to "0" setting, pull out plunger and tilt table until plunger is clear of 45 degree auto-stop. Then push in plunger and tilt until it rests against "0" setting auto-stop.

### Cross Beveling

Bevel cuts made across the grain also require a table tilt. The pass, however, is made with the miter gauge as in crosscutting. When the workpiece is long, lock the headstock and table at the right end of the tubes (Fig. 24). Length of work is then limited only by the distance between floor and ceiling.

### Compound Angle Cuts

Any type of framework with slanting sides requires a combination of miter gauge setting and table tilt (Fig. 25). The settings are determined by the work angle required and must be very exact. This is one of the more difficult cuts to accomplish but only because more care is required to obtain the extreme accuracy needed.

### The Extension Table

The SHOPS MITH extension table provides additional support when crosscutting long pieces and affords a maximum blade-to-fence dimension of 48" (Fig. 26). Even more than 48" can be obtained by removing the insert and advancing the quill. The full 48" is obtained with the extension table mounted at the left side of the tubes and the headstock and saw table locked at the right end of the tubes.

To set the extension table, use a long board to level it to the height of the saw table or bring the saw table close to the extension table and mate the top surfaces.

Hand grip locks at each end of SHOPS MITH are tightened by turning them upward; to release, merely turn in the opposite direction. If, for some reason you prefer a reverse action, loosen the hand grip until it may be removed from its slotted setting, reverse its position and tighten.

## Table Saw Accessories

### Miter Gauge Safety Grip

A MAGNA exclusive, this revolutionary miter gauge hold down (Fig. 27) is such a useful, practical accessory it should be a must in any craftsman's shop. All you have to do is grip the handle (which in itself facilitates handling the miter gauge) and the hold down automatically bears down on the work to keep it flat on the table and snug against the face of the miter gauge. You can accomplish cross-cutting, mitering, cross beveling, etc., easier, safer and with more accuracy than ever before possible. Molding head operations, shaping cuts, even many sanding jobs and drill press techniques are made easier with the Miter Gauge Safety Grip. Once mounted, which is a small assembly job since the SHOPS MITH M5 miter gauge is designed for the hold down, this accessory will prove so useful you will never remove it.

### Saw Blades

Most woodworkers like to have a full assortment of blades on hand (Fig. 28), and use each for the job it was designed to do.

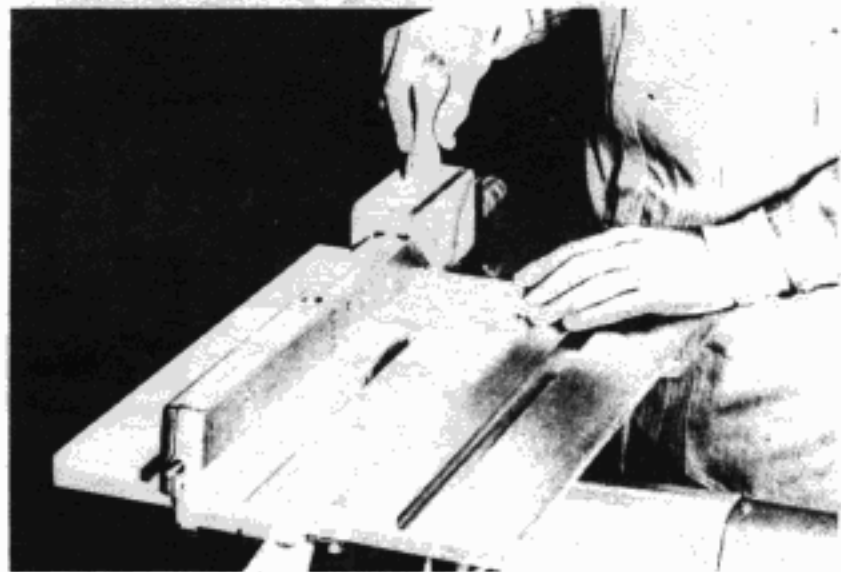

Fig. 21 Use a push stick on narrow cuts

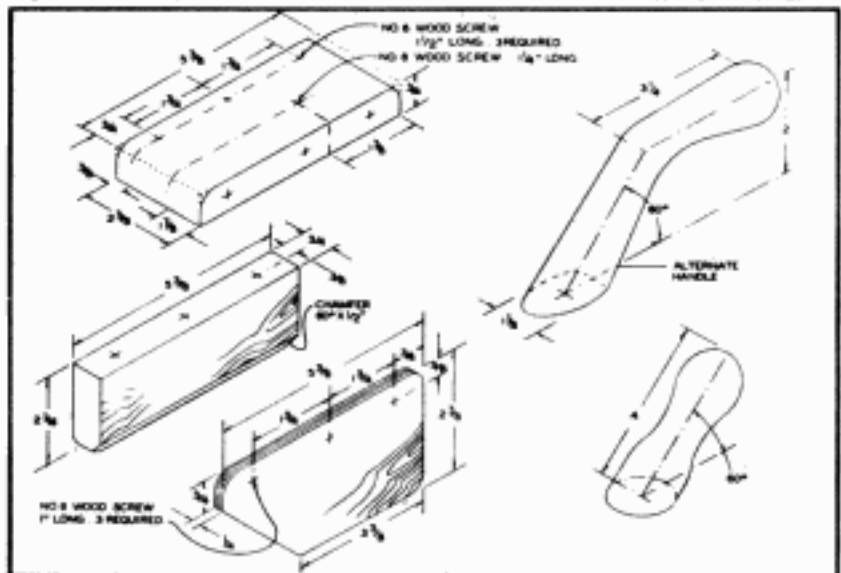

Fig. 22 Construction details of push stick

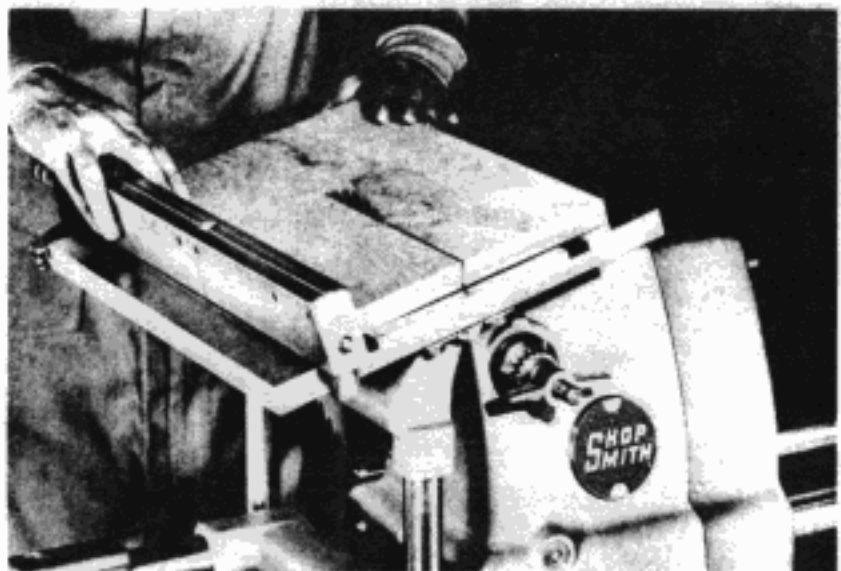

Fig. 23 Hand and body position on a bevel rip cut



Fig. 24 Cross bevel cut—saw at right end of tubes



Fig. 25 Compound angle is combination miter and bevel



Fig. 26 Plywood panels are easy to cut on SHOPSMITH M5

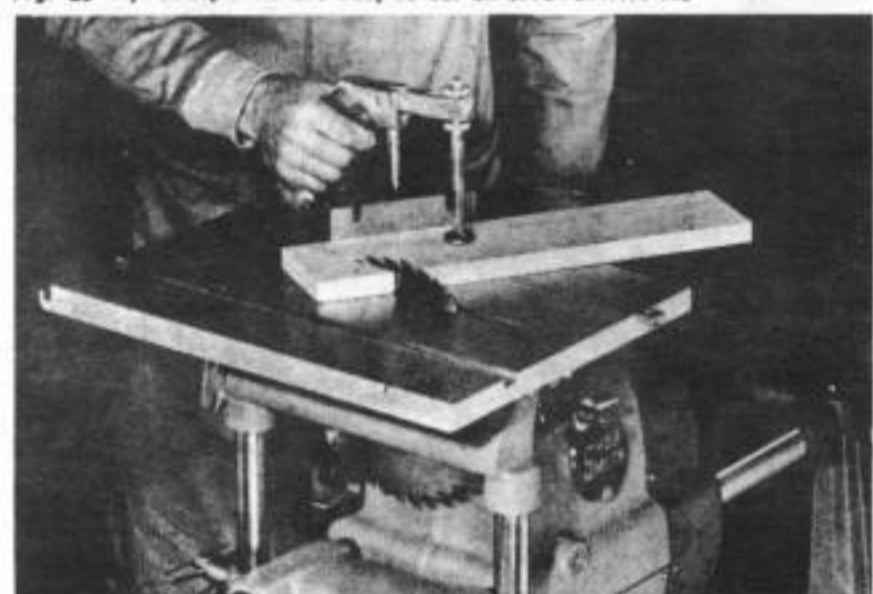

Fig. 27 Safety grip provides accuracy as well as safety

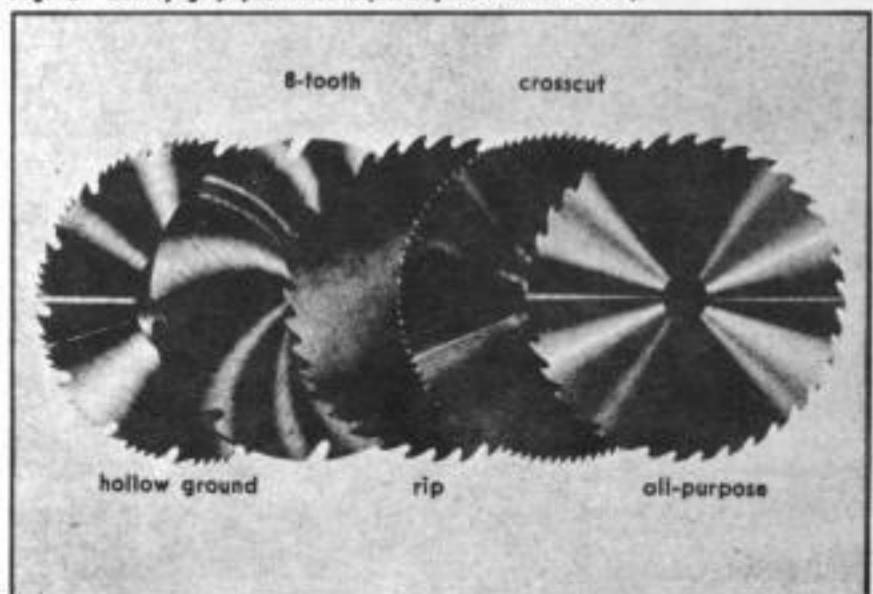

Fig. 28 SHOPSMITH M5 9" saw blades

The standard SHOPSMITH M5 blade is a combination type with a special tooth design and will do a good job on all general types of cutting. This is the workhorse of the shop and with reasonable care will do a good job for a long time.

The only blade available which will produce an edge smooth enough to glue or otherwise assemble without jointing or sanding is the hollow ground blade. This is usually the choice for a second blade. It should never be used for rough sizing cuts and should always be set so that it projects about  $\frac{3}{8}$ " above the work.

The rip blade is the best performer on ripping operations. The teeth are specially designed to act like tiny chisels, each cutting out a small amount of wood. The gullets between the teeth scoop out the waste. It does not produce a smooth cut but is excellent for production ripping and sizing cuts.

The crosscut, or cutoff blade as it is sometimes called, is the best performer for cutting across the grain. The teeth are designed to provide knife-like edges to left and right that shear across the grain of the wood. This is the blade to use when you have a lot of crosscutting to do.

The eight-tooth safety blade is a comparative newcomer in the field and has won popularity because of its anti-kickback characteristics. It is a combination blade, useable for both crosscutting and ripping.

### Arbors

Arbors (Fig. 29) are economically priced so that SHOPSMITH owners can make it a rule to have each saw blade and each applicable accessory ready-mounted, all set for placing on the SHOPSMITH spindle in seconds. Only with SHOPSMITH is this convenience available. The  $1\frac{1}{4}$ " arbor is used with 9" saw blades. The  $\frac{5}{8}$ " arbor is used for mounting saw blades and other accessories with a  $\frac{5}{8}$ " arbor hole. The  $\frac{1}{2}$ " arbor is used with accessories having a  $\frac{1}{2}$ " arbor hole. **ON THE AUXILIARY SPINDLE USE ONLY ARBORS HAVING A KEYWAY AND TONGUED WASHER (#22 030 and #22 031).** Ordinary arbors may be used on the main spindle but NEVER on the auxiliary spindle.

### Miter Gauge Extension

The miter gauge extension (Fig. 30) lends additional support and increases accuracy on such operations as crosscutting and mitering. It is made of sturdy hardwood and may be used with the miter gauge situated in either table slot. Some operators make a saw cut in the extension after it is mounted and thereafter use it as a guide for positioning work for crosscutting.

### Miter Gauge Stop Rods

Miter Gauge Stop Rods (Fig. 31) make it possible to do duplicate cutting by mechanical means. Once the rods are set, any number of pieces may be cut off to exactly the same length. This set is adjustable to gauge cutoffs

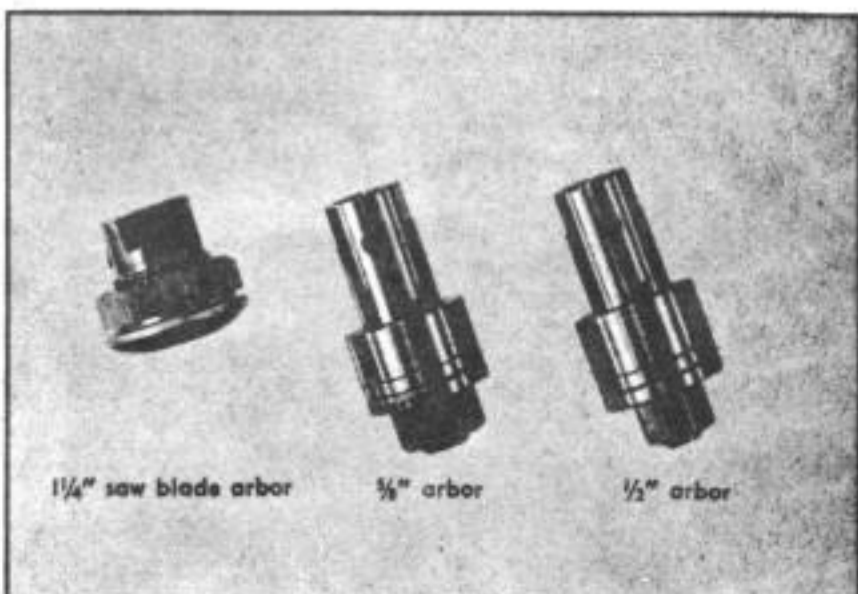

Fig. 29 Mount each accessory on its own arbor

up to 18" long. The short rod is locked in the miter gauge when short pieces are cut. When long pieces are required, the long rod is locked in the miter gauge.

### Front Table Extension

Although the SHOPSMITH table is large enough to accommodate most normal work for crosscutting, a front table extension (Fig. 32) will prove useful for those extra wide jobs. With the extension, the supporting area in front of the blade is increased to 14½".

### Dado Tools

A wide, recessed cut designed to take the edge of a board is cut with a dado. Of the two types available the MAGNA Dado is the most popular. It has a special extra heavy blade which cuts a normal kerf 5/32" wide and is infinitely adjustable to a maximum of ¾". Any width cut in between is possible with a simple Allen wrench adjustment. SPEEDIAL is engraved to indicate proper speed for MAGNA Dado use.

The 6" Dado Assembly is a standard tool which employs two outside blades and a set of inside chippers. The size of the groove is determined by the number and size of the chippers used between the blades.

Either dado tool must be used with a special Dado Insert which replaces the saw blade insert. This same insert is also used with molding head (Fig. 33).

### Cut-Off Wheel

The abrasive cut-off wheel (Fig. 34) is used like a saw blade to cut through steel, aluminum, copper, brass, plastics, asbestos, masonite, and other similar materials in sheet, bar or extruded forms. It may be used for light honing jobs on small cutting tools and knives **BUT NOT FOR ANY OPERATION THAT WILL EXERT SIDE PRESSURE AGAINST THE DISC.** The cut-off wheel should be mounted between extra large flanges. The operator should wear Safety Goggles and should protect SHOPSMITH tubes from dirt and grit. **IT SHOULD NOT BE USED FOR CUTTING WOOD OR FOR DIMENSIONAL GRINDING.**

### MAGNA Molder

The MAGNA Molder (Fig. 35) makes it possible to do edge and surface molding operations on the table saw. It enables even the beginner to increase the scope of his woodworking projects and will add a professional touch to the simplest construction. The MAGNA Molder mounts directly on the SHOPSMITH spindle or can be used with a 5/8" arbor.

Here are some of the jobs you can do with the MAGNA Molder: — mold decorative edges, form glue joints, tongue and groove joints, make 1½" sash, form countless variations of moldings, cut rabbets and grooves and many other operations which would be tedious or difficult to do otherwise.

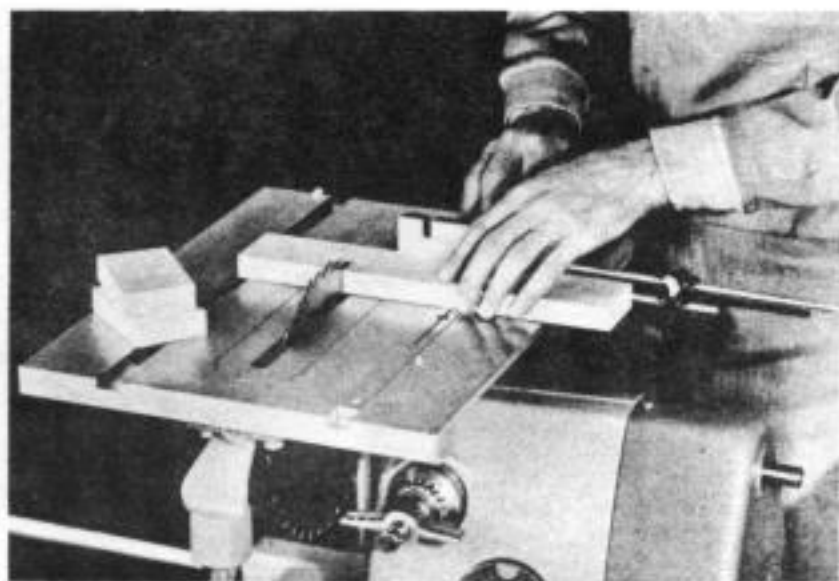

Fig. 31 Miter gauge stop rod gauges duplicate lengths

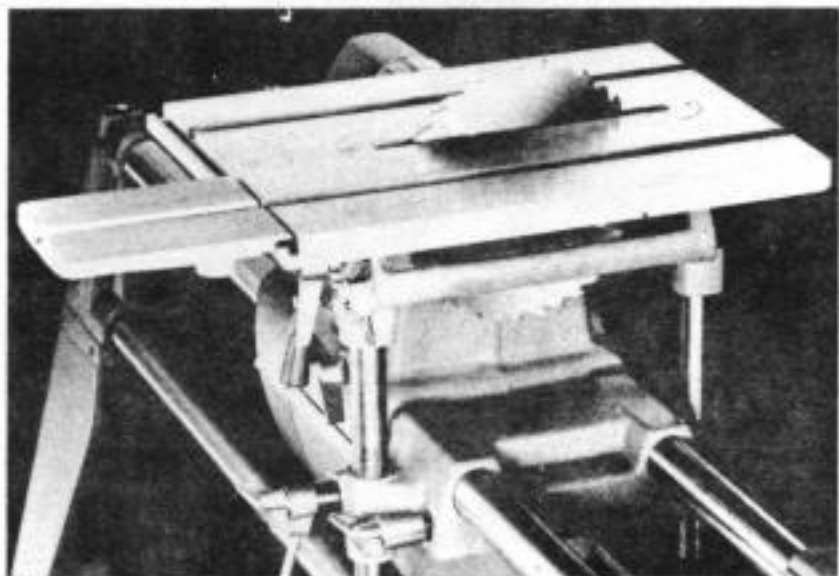

Fig. 32 Front table extension mounted on saw table

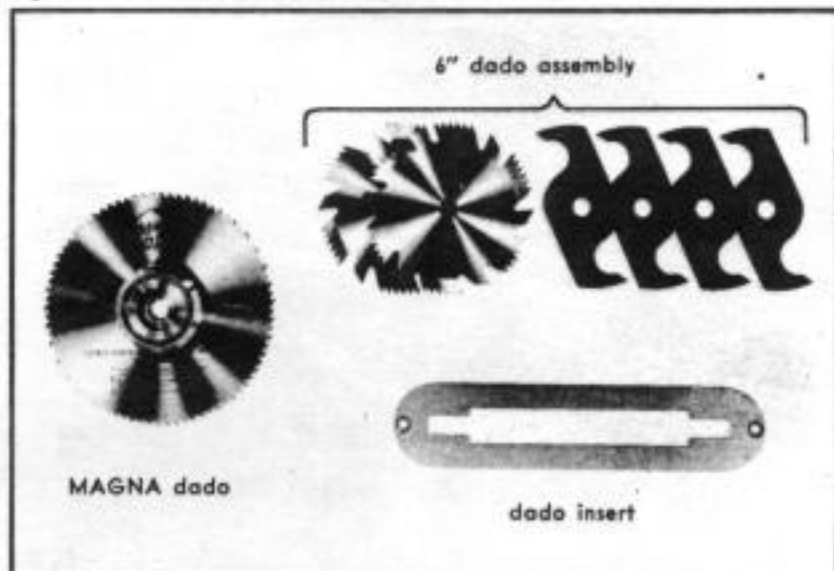

Fig. 33 Accessories for cutting dados, grooves, etc.

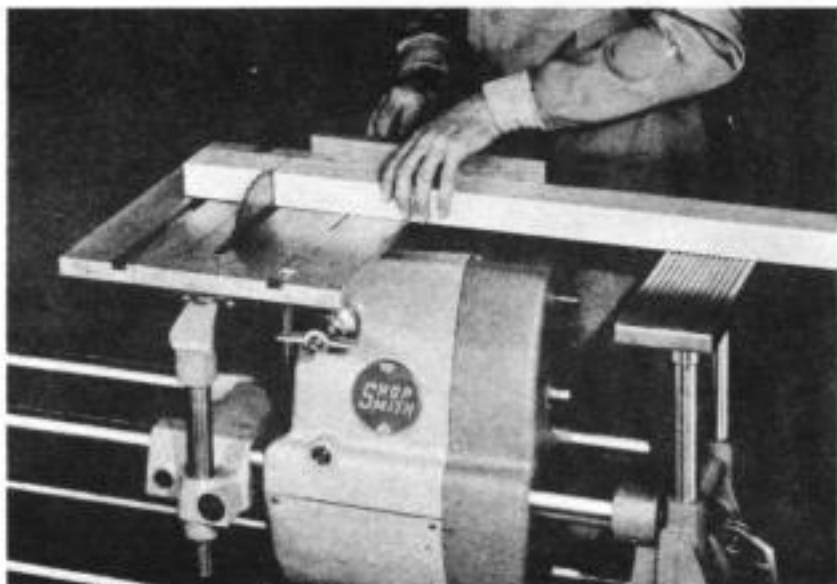

Fig. 30 Miter gauge extension in use

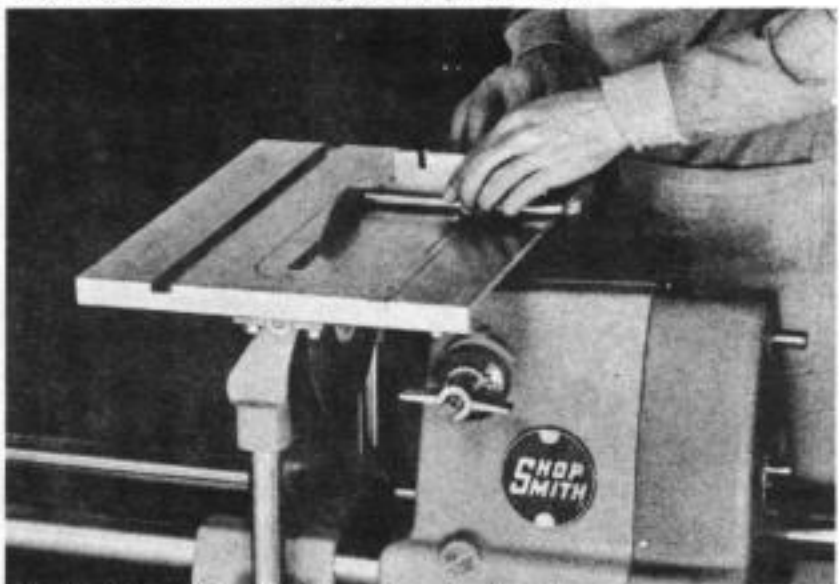

Fig. 34 Obey safety rules when using cut-off wheel

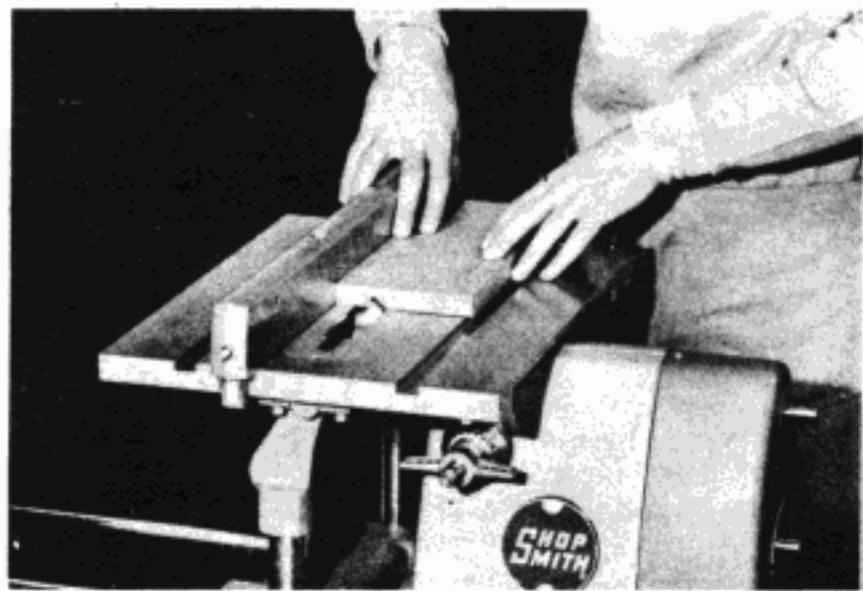

Fig. 35 Surface cutting with MAGNA Molder

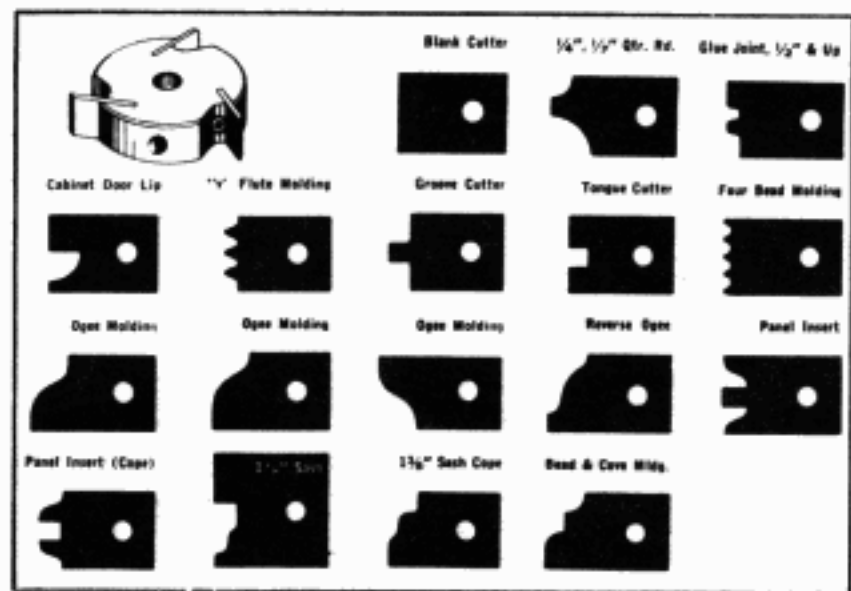

Fig. 36 Profiles of MAGNA molding knives

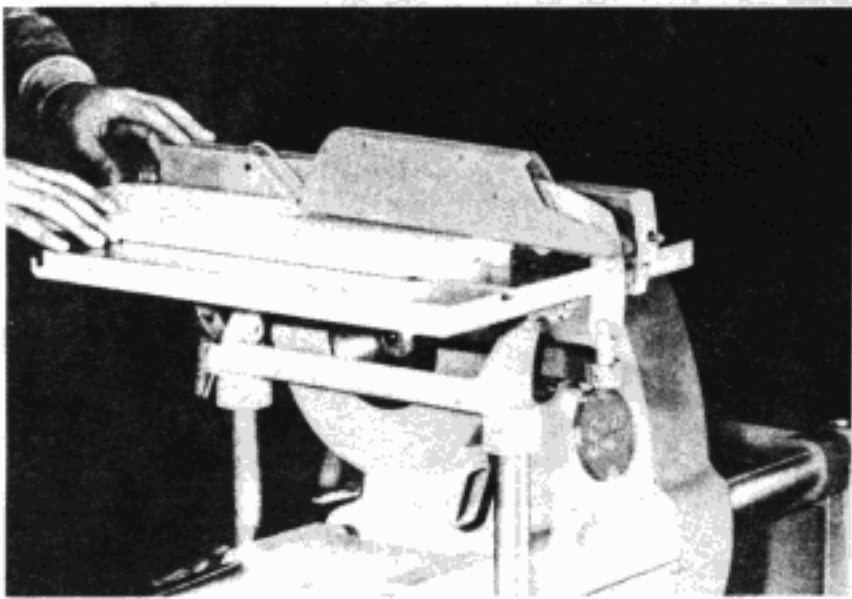
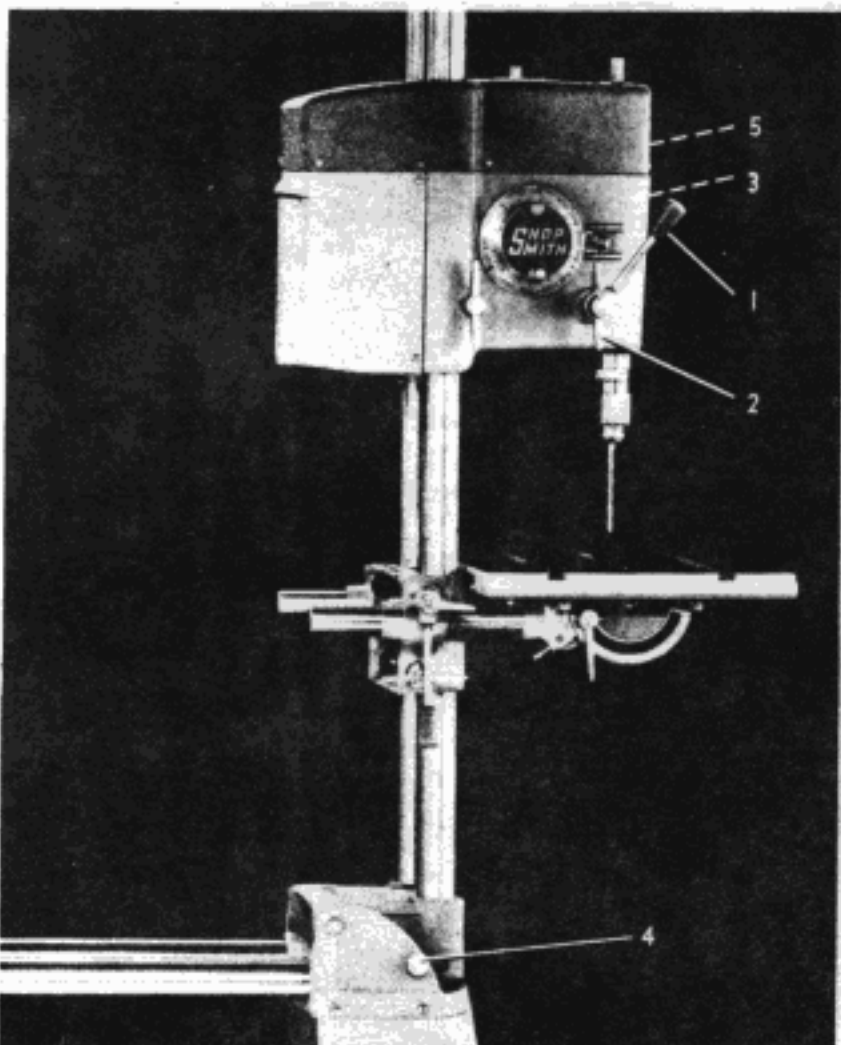

Fig. 37 SHOPSMITH M5 saw guard

### SHOPSMITH M5 Saw Guard

Here is the ultimate in saw guard design (Fig. 37). Includes upper guard which automatically adjusts itself to the thickness of the stock being cut, lower guard which conceals the saw under the table and also provides a sawdust chute, splitter to keep the kerf from closing and thus binding the blade, and anti-kickback fingers with rubber covered edges which grip the wood tightly yet do not mar it as serrated types do.

The upper guard covers the blade at all times but does not obstruct vision. The front of the upper guard has a plastic window.



### The Drill Press

1. **Quill feed lever** . . . May be used on either side of headstock. Positions radially merely by unscrewing a few turns.
2. **Quill lock** . . . Turning clockwise locks quill in any extended position for routing, shaping, and many other operations.
3. **Feed stop** . . . Turning clockwise locks setting for controlled depth drilling.
4. **Base plate knob** . . . Locks SHOPSMITH in vertical drill press position.
5. **Depth control dial** . . . Dial to depth setting required. Setting locked with feed stop.

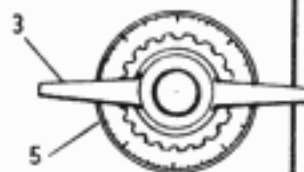

Dial depth control on 4 1/4" quill feed is simple and accurate . . . simply turn dial to the setting required and lock . . . no inconvenient stop nuts or rods.

Fig. 38 SHOPSMITH M5 vertical drill press

# How to Use the Drill Press

## Setting Up

Raise table to highest point and tilt until two cap screws underneath table rest on tubes. Secure setting with table tilt lock and use a square to check the angle of the table to the tubes. If it is not exactly 90 degrees, the two cap screws must be adjusted so they will serve as automatic stops. Loosen the jam nuts and thread the screws in or out until the angle is correct. Tighten the jam nuts. This check should be made the very first time you set up SHOPSMITH M5 in vertical drill press position.

Lock the carriage at a point about 15 inches from the base plate. Lock the headstock so that there is about 10 inches between spindle and table. **BE SURE BOTH HEADSTOCK AND CARRIAGE ARE LOCKED SECURELY.** Lift up headrest lock lever and then, gripping tubes behind headstock, lift SHOPSMITH to vertical position. Lock base plate knob.

Position of headstock and carriage on tubes may be varied to give most convenient working level relative to operator's height.

## Drilling

Drill bits and other cutting tools (except those which require special chucks because of side thrust) are secured in the Jacobs three-jaw chuck with the chuck key. **BE SURE TO REMOVE THE KEY BEFORE TURNING ON THE MOTOR.** Before drilling, check the speed chart for correct rpm. Always use a scrap block between the work and the table.

Quill feed should be steady so the drill will always be cutting (Fig. 40). On very deep holes it is good practice to retract the drill frequently to clear chips from the hole.

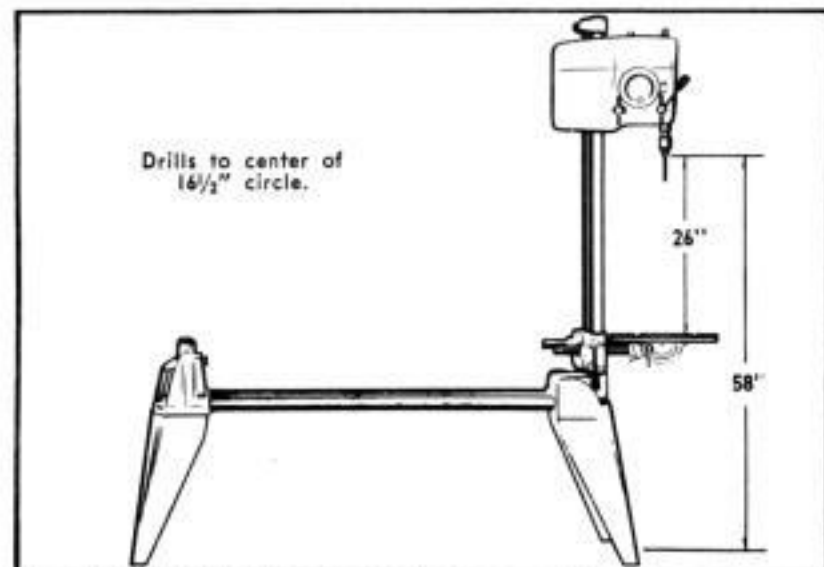

Fig. 39 SHOPSMITH M5 vertical drill press capacities

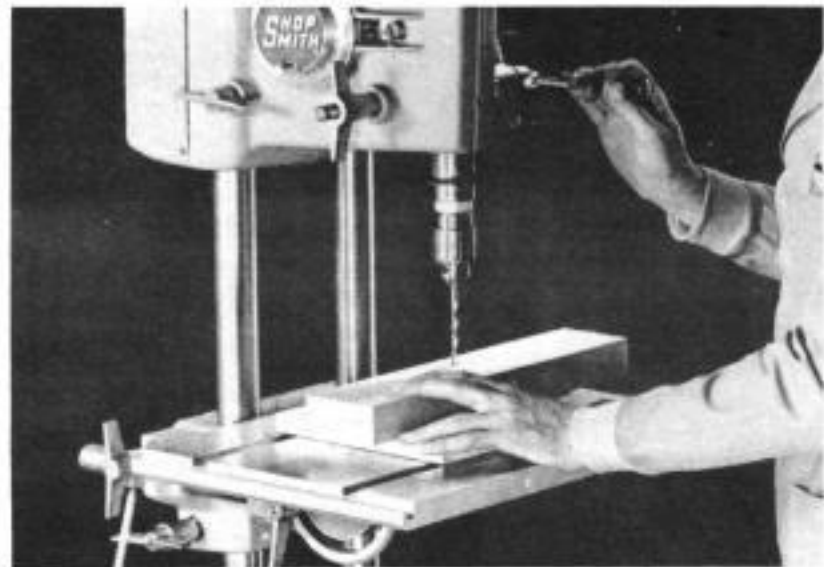

Fig. 40 Use scrap block between work and table

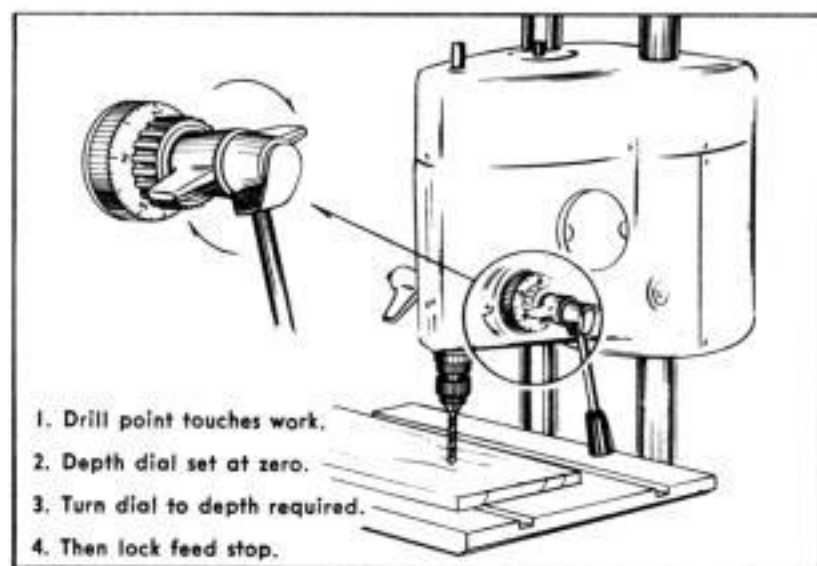

Fig. 41 Setting depth control dial

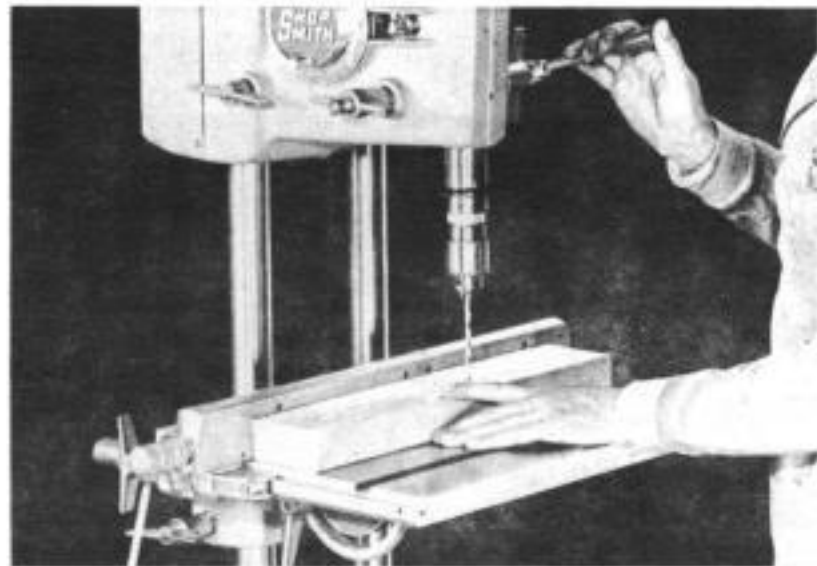

Fig. 42 Using rip fence for parallel drilling

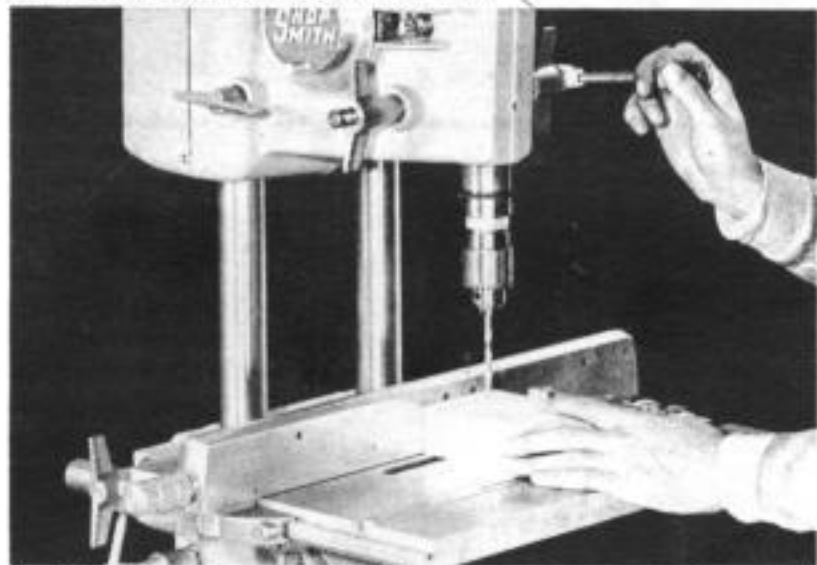

Fig. 43 Using miter gauge and rip fence as a jig



Fig. 44 V-Block jig for drilling round stock

It should never be necessary to force the drill. If it isn't cutting cleanly, smoothly and easily you may be using the wrong speed or a dull drill.

When drilling metal or large holes in wood be sure to clamp the work to the table. A drill can catch in the hole, especially when breaking through, and twist the work out of your hands.

### Controlled Depth Drilling

When it is necessary to control quill extension, as in drilling to predetermined depth, or mortising, extend the quill until the drill point touches the work. Turn the depth control dial (Fig. 41) clockwise to the setting desired and secure with the feed stop. The quill will then extend that further amount. To hold the quill in any extended position use the quill lock.

### Parallel Drilling

The rip fence is an excellent guide for maintaining edge distance on a series of holes (Fig. 42). Merely lock the fence so that the distance from the side of the fence to the drill point is equal to the distance from the edge of the work to the center of the hole. On SHOPSMITH this is done very accurately by locking the fence in an approximate position and then using the table height lever as a forward feed mechanism to make the final critical adjustment.

### Jig Drilling

The rip fence and miter gauge may be utilized as jigs for duplicate drilling (Fig. 43). Locate hole position on one piece of stock and set fence and miter gauge to position the work. The miter gauge is locked in place with the miter gauge bar lock screw so that no clamps are needed. Then you merely place each piece in position and drill the hole.

### V-Block Drilling

Diametrical holes are easily drilled on SHOPSMITH merely by tilting the table to 45 degrees and setting the rip fence so that the point of the drill is exactly centered in the "V" thus created. The V-block both holds the work and positions it for accurate drilling (Fig. 44).

### Floor Model Drill Press

SHOPSMITH may be utilized as a floor model drill press merely by tilting the table until it is parallel to the tubes and adjusting it to gauge the position of the work. Mortising or drilling for door locks is typical of the operations conveniently handled with this setup (Fig. 45).

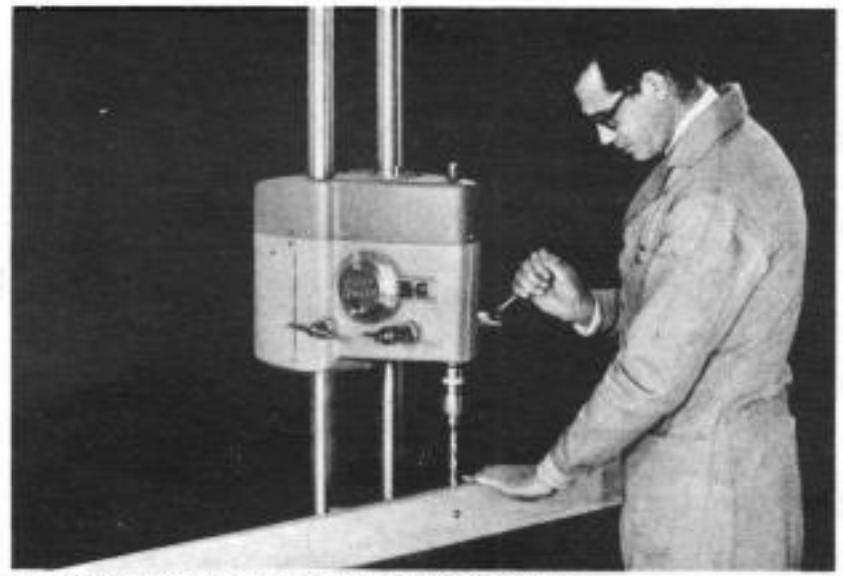

Fig. 45 SHOPSMITH M5 as a floor model drill press

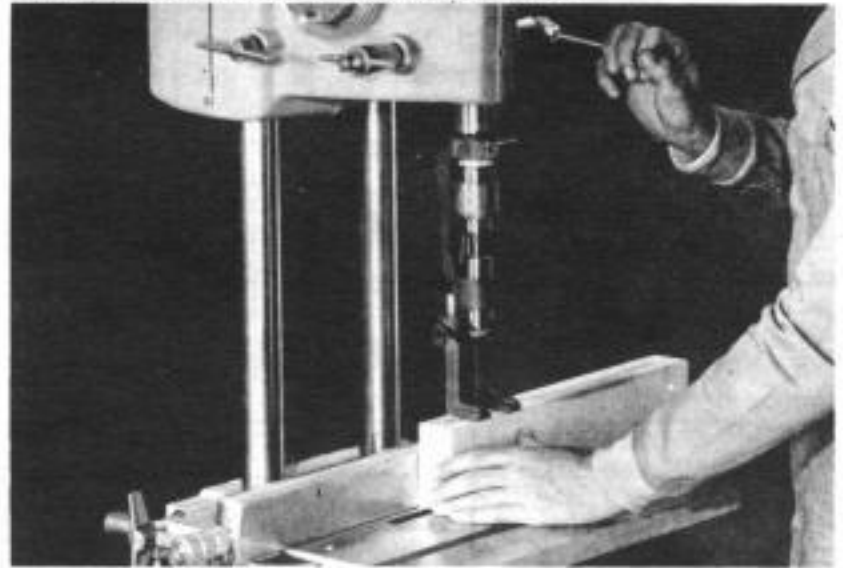

Fig. 46 Cutting a mortise

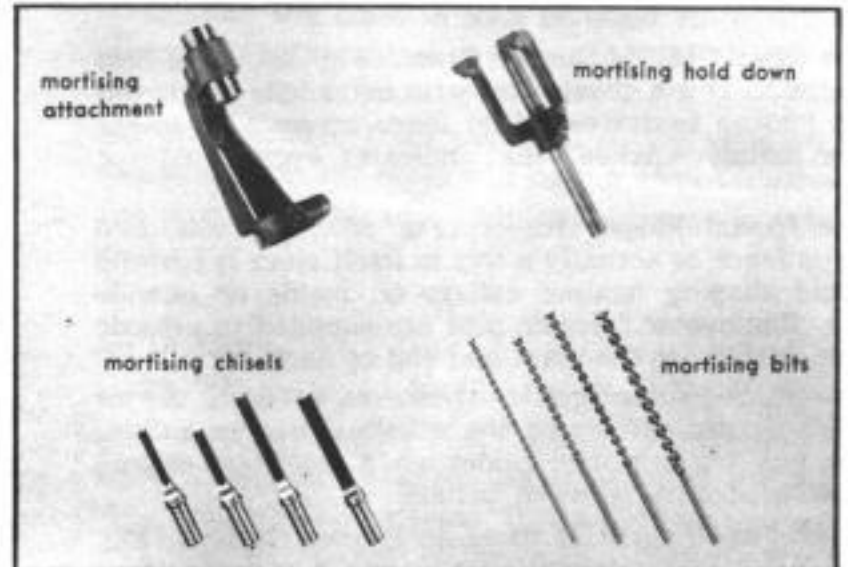

Fig. 47 Accessories for mortising

## Drill Press Accessories

### Mortising

The mortise and tenon joint is very widely used in cabinet and furniture construction. The tenon, which is an integral projection cut on one of the mating pieces, is usually formed on the table saw or jointer but the mortise, the cavity which receives the tenon, must be formed with mortising bits and chisels (Fig. 46). Actually, mortising attachments enable you to form square holes on the drill press, a cut which may be utilized in operations other than mortise forming.

The mortising attachment is easily attached to the quill collar and is needed to hold and position the square mortising chisel. The hold down, which locks in the hole at the top of the rip fence, prevents the work from pulling off the table when the chisel is retracted.

### Shaping

Shaping accessories (Fig. 48) enable you to form intricate edge designs or moldings that mean so much to the final appearance of a project.

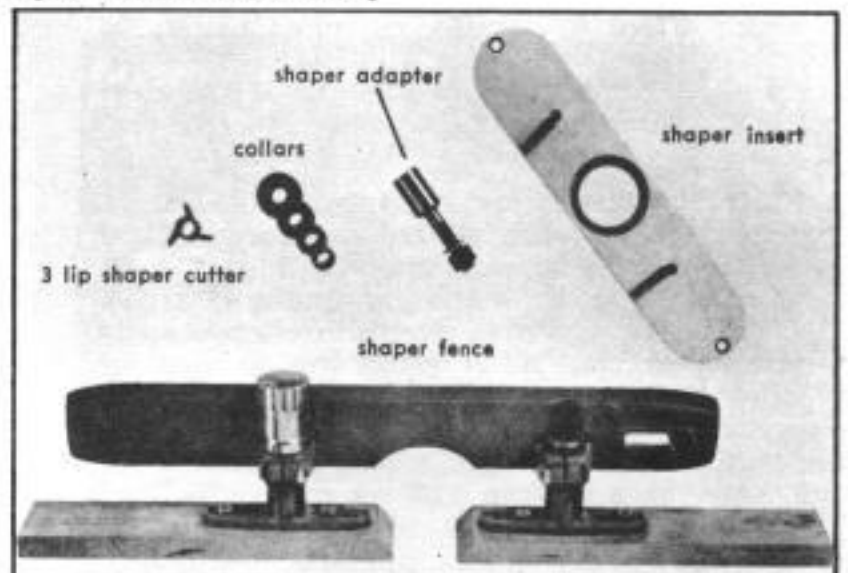

Fig. 48 Accessories for shaping

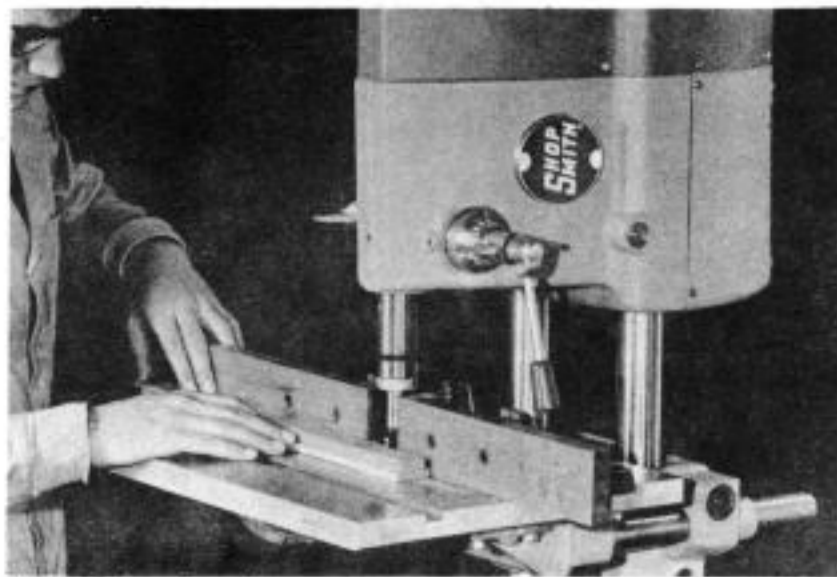

Fig. 49 Shaper fence in use

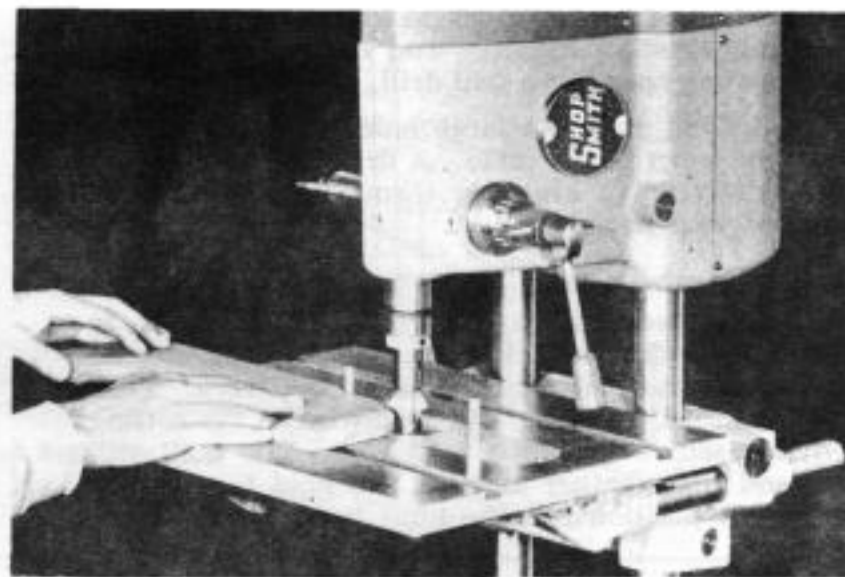

Fig. 50 Shaping curved stock with shaper insert

THREE-LIP SHAPER CUTTERS Mount on SHAPER ADAPTER Use with SHOPSMITH SHAPER FENCE		Bead Molding	Crown Molding	Comb. Bead & Qtr. Rd.
$\frac{1}{2}$ " & $\frac{1}{4}$ " Qtr. Rd.	Groove Cutter	Yogee Cutter	Blank Cutter	Blank Cutter
Bead and Bevel	Qtr. Rd. & Comb	Slab Jnt. $\frac{1}{2}$ " & $\frac{3}{8}$ "	Clover Leaf	3 Bead and Bevel
Bead & Comb Molding	Cabinet Door Lip	Drop Leaf Joint Cutters Drop Leaf Edge	Table Edge	Table Edge Drop Leaf Drop Leaf Down

Fig. 51 Profiles of 3-lip shaper cutters

The SHOPSMITH Shaper Fence (Fig. 49) is the best in the field. It is a strong unit with extra long hardwood fences and an exclusive infeed fence screw adjustment with a spring "clicker" that indicates every  $\frac{1}{64}$ " of adjustment.

The special Shaper Insert (Fig. 50), which is used with the fence, is actually a tool in itself since it permits freehand shaping against collars on inside or outside curves. Removable fulcrum pins are supplied to provide bearing surface at the start and end of each cut.

The Shaper Adapter is used like an arbor to mount three-lip shaper cutters on the spindle. Shaper collars are used as depth control guides when shaping freehand and also as spacers between cutters.

A good assortment of three-lip Shaper Cutters (Fig. 51) is available. Some have profiles which will reproduce standard molding or joint forms. Others are combination cutters which afford a virtually unlimited variety of shapes by making several passes with the same cutter, changing depth of cut or height of cutter after each pass, or by combining partial cuts with several cutters.

### Routing

SHOPSMITH makes it easy to do routing operations. The table height lever when utilized as a forward feed mechanism can be used for cross-grain routing. The rip fence is an excellent guide for straight routing (Fig. 52). SHOPSMITH's large table area affords excellent support for oversize pieces. The miter gauge can be used for routing cross-grain and it may be locked in position for stop routing. In addition, the countersunk hole at the free end of the miter gauge may be utilized for mounting a pin; thus you can do pivot routing.

Because of the side thrust which is developed, router bits should be held in special router chucks.

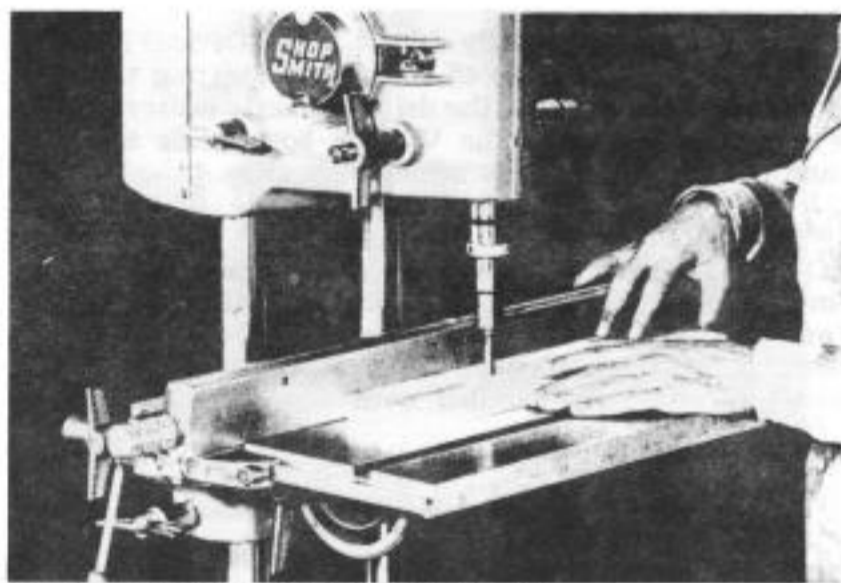

Fig. 52 Rip fence as a guide for straight routing

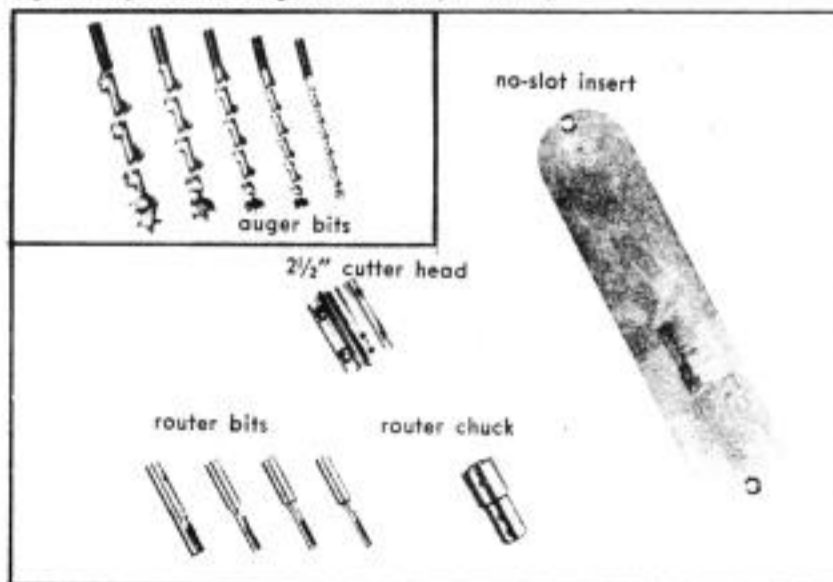

Fig. 53 Other drill press accessories



## The Horizontal Drill Press

SHOPSMITH gives you the only adequate horizontal drill press available in the homecraft or light industrial field. Properly utilized it will facilitate many operations which are time-consuming, inconvenient, or actually impossible on a vertical drill press.

### How to Use the Horizontal Drill Press

The following are but a few examples which typify operations best handled in horizontal drill press position.

#### Drilling for Butt Dowel Joints

Drilling edge holes for a butt dowel joint is easily accomplished in wide or narrow boards with the setup shown in Fig. 54. The rip fence is locked in place to act as a backstop and as a guide to hold the work square to the drill. The feed stop is locked to control hole depth. The only dimension line needed on the board edges is distance between holes. It is not necessary to center the holes between edges if the operator makes certain to place the same side of each board down on the table.

To mark the dimension lines for distance between holes, hold the boards together and butt one end against the rip fence. The miter gauge is an excellent tool for marking the lines across the edges of the boards.

#### End Drilling

Drilling end holes in long or short stock is done by locking the miter gauge in place to act as a guide for the work (Fig. 55). If you position the work accurately you can drill through from each end of the piece with the assurance that the holes will have a common centerline. The extension table adds additional support for extra long work.

#### Jig Drilling

Fig. 56 shows how easy it is to set up for drilling dowel holes in mitered pieces. Lock the miter gauge in place to act as a stop and guide for the work and clamp the work to the table before drilling. It is a good idea to set up so that aligning the front of the work with the front edge of the table positions it to maintain uniform hole depth.

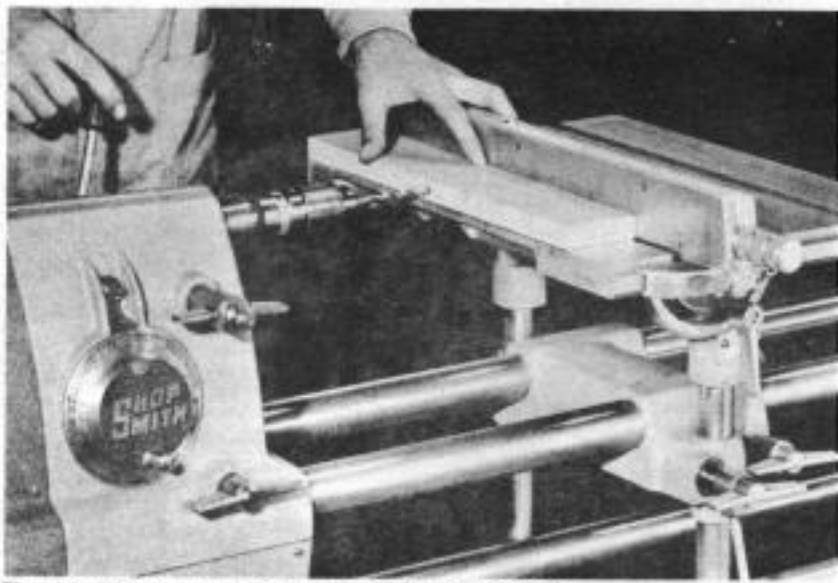

Fig. 54 Drilling dowel holes in horizontal position

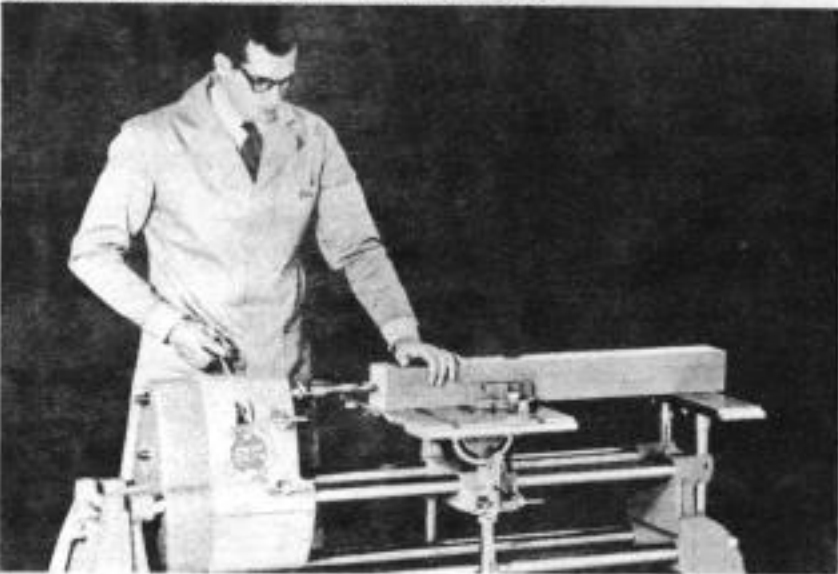

Fig. 55 Drilling end hole in horizontal position

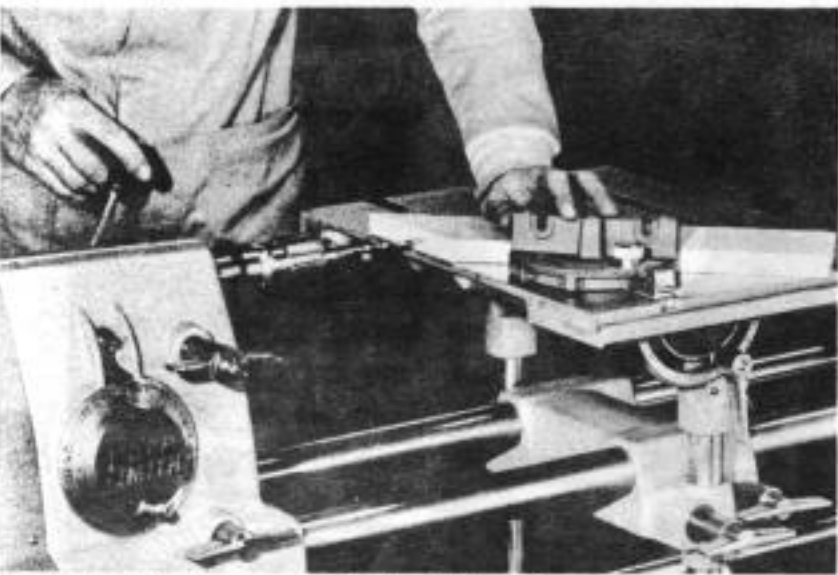

Fig. 56 Locked miter gauge is jig for drilling miter



Fig. 57 How to set up for concentric drilling

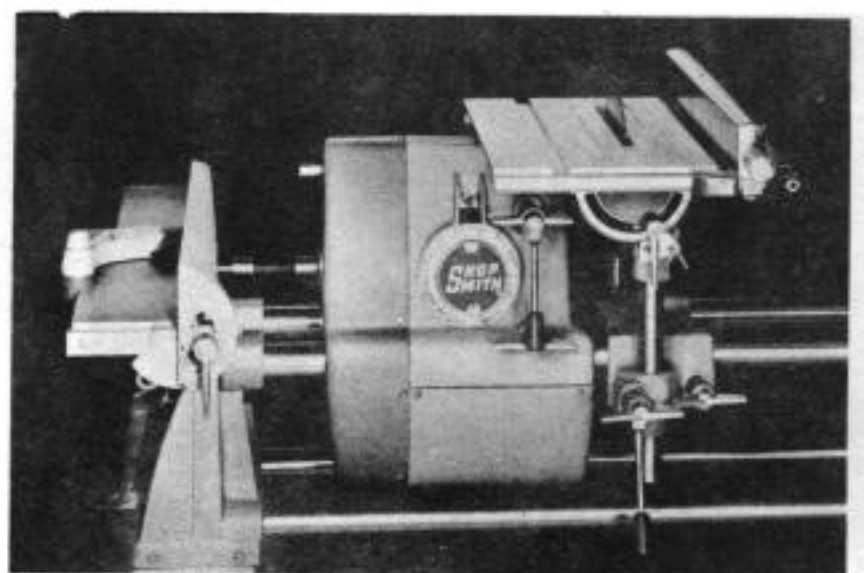

Fig. 58 SHOPSMITH is perfect saw-jointer combination

## Concentric Drilling

Concentric holes needed in lamp bases and similar projects are easily drilled as shown in Fig. 57. The tail-stock and cup center (see section on **THE LATHE**) are mounted in the base plate. One end of the work is positioned on the cup center and the other end centered with the drill bit. Raise the table to support the work and lock the miter gauge in place to act as a stop and guide.

## The Horizontal Spindle

Conventional counterpart of the horizontal spindle is the polishing head which requires its own stand and motor and which is limited in function, size and capacity. With SHOPS MITH M5 you have a double-end spindle plus quill action, plus variable speed for any tool or operation.

The double-end spindle makes possible dual mounting of complementary tools. Not only the traditional saw-jointer setup (Fig. 58) but other worthwhile combinations.

You can, for example, mount one sanding disc in its normal position and a second one with a different grit paper on the upper auxiliary spindle using the extension table to support the work (Fig. 59).

The SHOPS MITH jigsaw can be mounted in its normal position (receives its power through the upper auxiliary spindle) and the main spindle utilized to run a drum or disc sander (Fig. 60).

You can combine a disc or drum sander with a buffing wheel or a buffing wheel with a polishing pad—either of these combinations is excellent for polishing plastics—or a disc sander can be combined with a drum sander.

When mounting accessories on the auxiliary spindle be sure to use arbors with a keyway and tongued washer—accessory #22 031 ( $\frac{5}{8}$ " arbor) and accessory #22 030 ( $\frac{1}{2}$ " arbor). These are designed to prevent the arbor nut from loosening regardless of direction of rotation and may be used on front or rear spindles. **NEVER USE A CONVENTIONAL ARBOR HAVING A RIGHT HAND THREAD ON THE AUXILIARY SPINDLE.**

Before mounting combinations check operational speeds of each. The Rubber Bonded Abrasive Wheel mounted on the rear spindle is very useful for keeping lathe chisels sharp as you are turning **BUT BE SURE THE LATHE TURNING DOES NOT REQUIRE SPEEDS IN EXCESS OF MAXIMUM SPEED FOR THE ABRASIVE WHEEL.** Never combine any tool requiring a speed in excess of 2000 rpm with the disc sander since that is top speed for the disc.

The general rule is, **ALWAYS LET THE TOOL WITH THE LOWEST MAXIMUM SPEED GOVERN THE COMBINATION.**



Fig. 59 Dual sanding is possible on SHOPS MITH M5

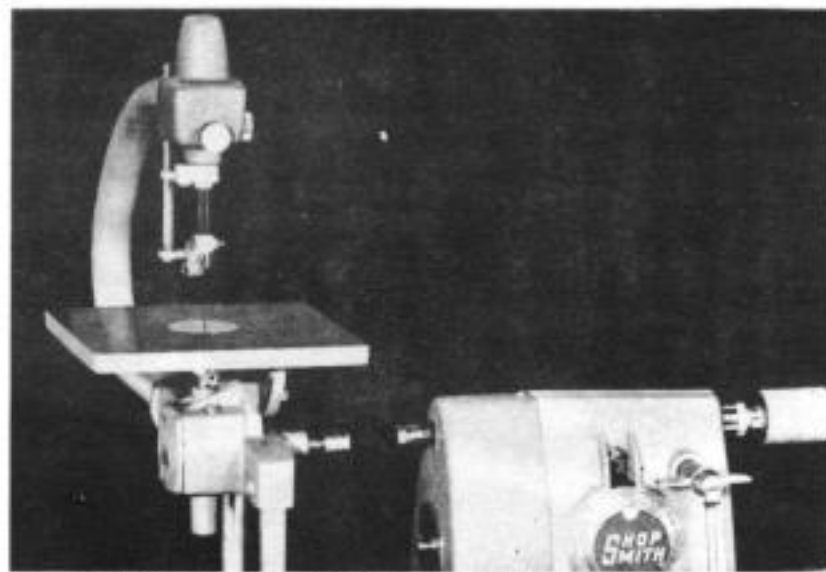

Fig. 60 Jigsaw and drum sander combination



Fig. 61 Wire brushing Fir plywood for sculptured effect



Fig. 62 Buffing copper planter

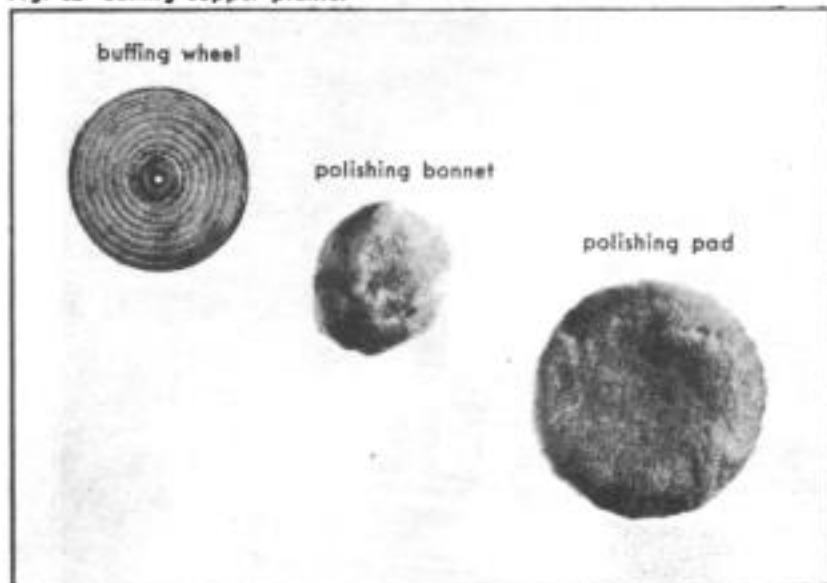

Fig. 63 Polishing and buffing accessories

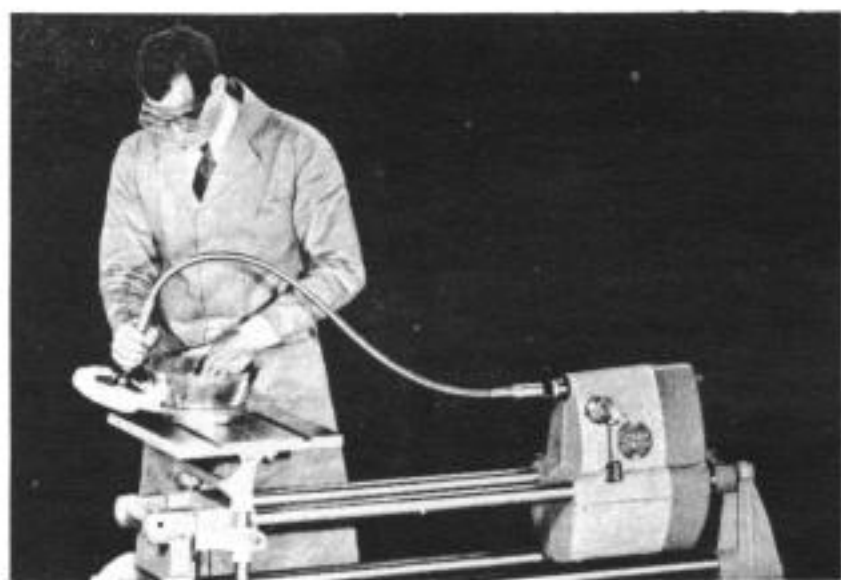

Fig. 64 Flexible shaft in use



Fig. 65 The ideal honing tool

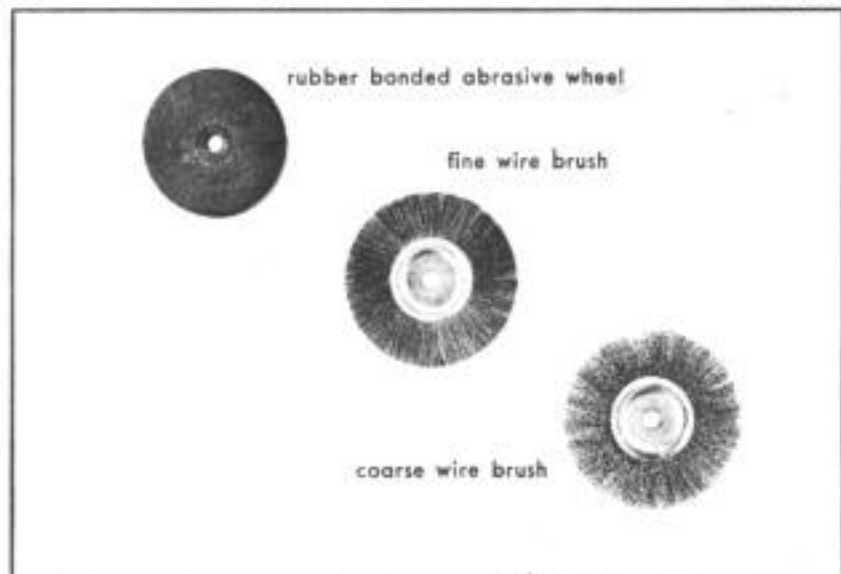

Fig. 66 Wire brushes and rubber bonded abrasive wheel

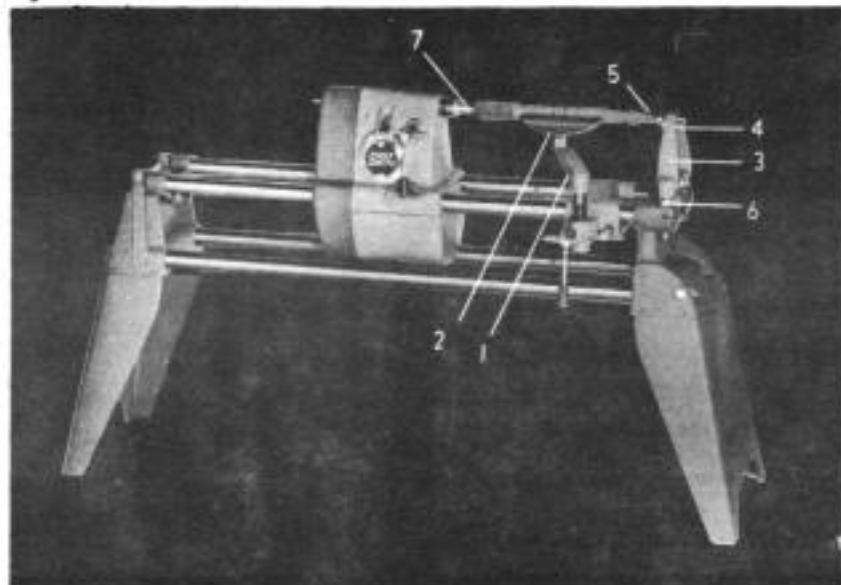

Fig. 67 SHOPS MITH M5 lathe

## Wire Brushing

Coarse or fine wire brushes enable you to get satin finishes on various metals, do deburring jobs, clean solder joints, remove rust and do many other jobs around the home or workshop. Encrusted kitchen utensils can be cleaned by wire brushing and items like golf clubs easily refinished.

Wire brushing also makes it possible to achieve the popular sculptured effect on wood (Fig. 61). It is merely a matter of holding the wood against the turning wheel, moving it slowly in grain direction. The wire removes the soft wood, leaving the hard grain and giving a shadowed three dimensional effect.

## Polishing and Buffing

Accessories are available which enable you to do a quick, easy job of such household chores as putting a high shine on the family shoes. Plastics and metals (Fig. 62) may be cleaned and polished by using a buffing wheel, polishing pad or bonnet. The polishing bonnet is made so it can be used over the drum sander. The polishing pad fits neatly over the 6" face plate.

## Flexible Shaft

The flexible shaft makes a portable tool out of many of the accessories normally used on the SHOPS MITH spindle (Fig. 64). Arbor mounted tools, or the Jacobs chuck, attach to the tapered flat spindle end of the flexible shaft just as they do on SHOPS MITH. Power is received through the main spindle.

**CAUTION:** The flex shaft should never be used on the rear auxiliary spindle since this would reverse normal direction of rotation. The attachments may loosen and the shaft may be damaged.

## Rubber Bonded Abrasive Wheel

This is an excellent tool for putting a keen, sharp edge on plane blades, kitchen knives, scissors, etc.; and for touching up lathe chisels while you are turning (Fig. 65). It is also good for polishing and deburring jobs. **IT SHOULD NOT BE USED FOR DIMENSIONAL GRINDING OPERATIONS.**

### CAUTION

Always operate sanding, polishing, cleaning and sharpening tools at recommended speeds and always wear Safety Goggles. Stand aside so that you will not be in line with the turning tool. Protect SHOPS MITH tubes from dirt and grit.

## The Lathe

1. **Tool rest arm** . . . Supports tool rest—rack adjustable up or down—swings 360 degrees.
2. **Tool rest** . . . Locks in tool rest arm—used as guide and support for lathe chisels—swings 360 degrees.
3. **Tailstock** . . . Locks securely in base plate—supports eccentric cup center mount.
4. **Eccentric cup center mount** . . . Locks in place with Allen screw—permits offset turning for tapers.
5. **Cup center** . . . #2 Morse Taper—supports spindle turnings at tailstock end.
6. **Height collars** . . . Correct tailstock height always maintained after initial setting.
7. **Drive center** . . . Attaches to spindle—has point for centering work; spurs for non-slip grip.

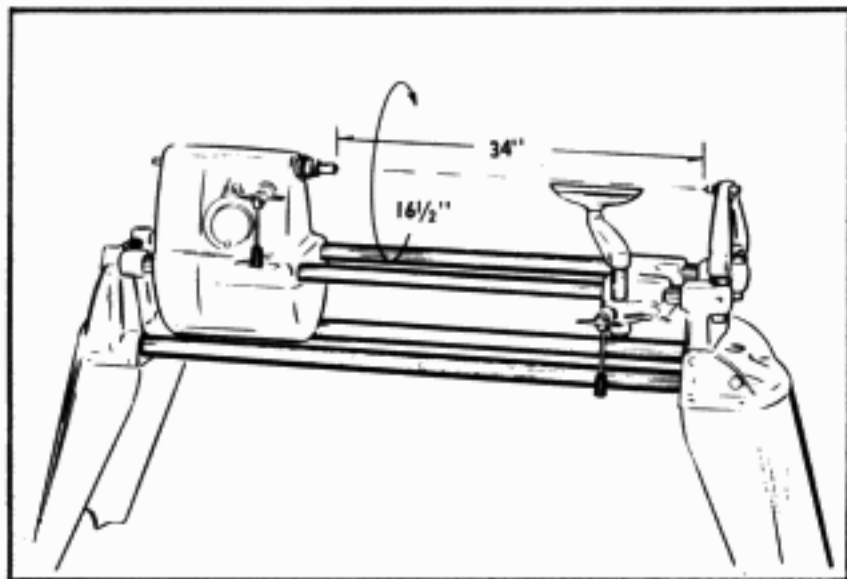

Fig. 68 SHOPSMITH M5 lathe capacities

## How to Use the Lathe

Points on drive and cup centers should be in perfect alignment. To check, bring headstock to right end of tubes. Extend quill until spur point almost touches cup point. Look down on the points and if they are not in perfect vertical alignment loosen cup center mount screw and turn cup center mount to bring cup point in line with drive point. Lock cup center mount.

Raise or lower the tailstock to achieve horizontal alignment. When the setting is correct, lock the height rings on the tailstock tubes.

### Mounting Spindle Work

Stock for spindle turning is usually cut square before it is mounted. Next step is to draw intersecting diagonals across each end of the stock (Fig. 69). Use an awl to form a small hole at each intersection. Seat the drive center at one end of the stock by tapping it in place with a mallet (Fig. 70). Place one end of the stock against the cup point and bring up the headstock so that the drive center, which you have attached to the spindle, is about  $\frac{1}{4}$ " away from the other end of the stock. Lock the headstock and advance the quill to engage the work (Fig. 71). Press the spur firmly in place and then retract the quill just a fraction to eliminate binding and burning the wood at the cup point end.

### Adjusting Tool Rest

The tool rest is adjusted as shown in Fig. 72. This is the ideal condition and should be approximated as closely as possible at all times. Naturally, because the size of the work diminishes with successive cuts, it is impossible for the tool rest to remain in one fixed position. As turning proceeds, adjust the tool rest to give maximum support to the chisels.

### Offset Turning

The SHOPSMITH M5 eccentric cup center mount, combined with the controlled parallelism of the tool rest makes turning tapers an almost automatic job. The cup center mount is calibrated in 16ths of an inch with a maximum offset of  $\frac{1}{2}$ ". To use it, turn the stock to full round, maximum diameter of the design. Turn the cup center mount to the offset needed. Lock in place and raise tailstock to bring points back into horizontal alignment.

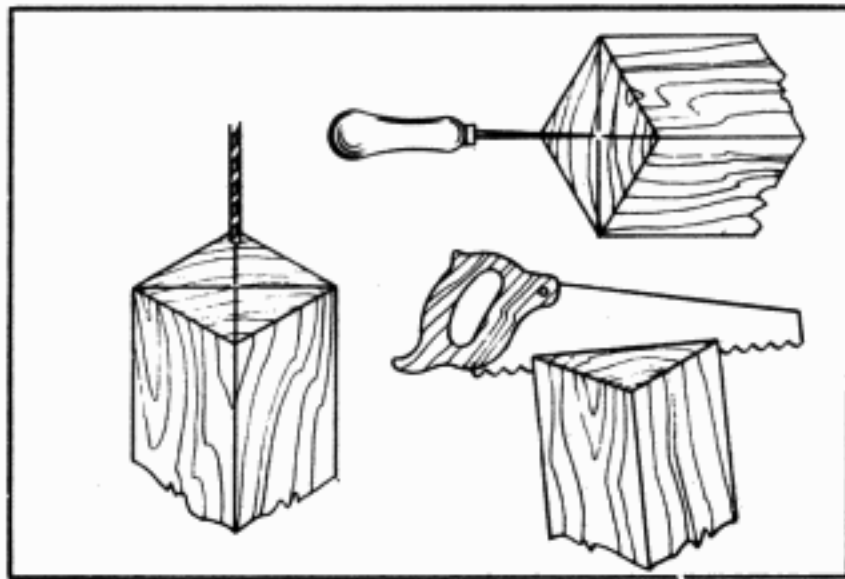

Fig. 69 Marking spindle work for mounting

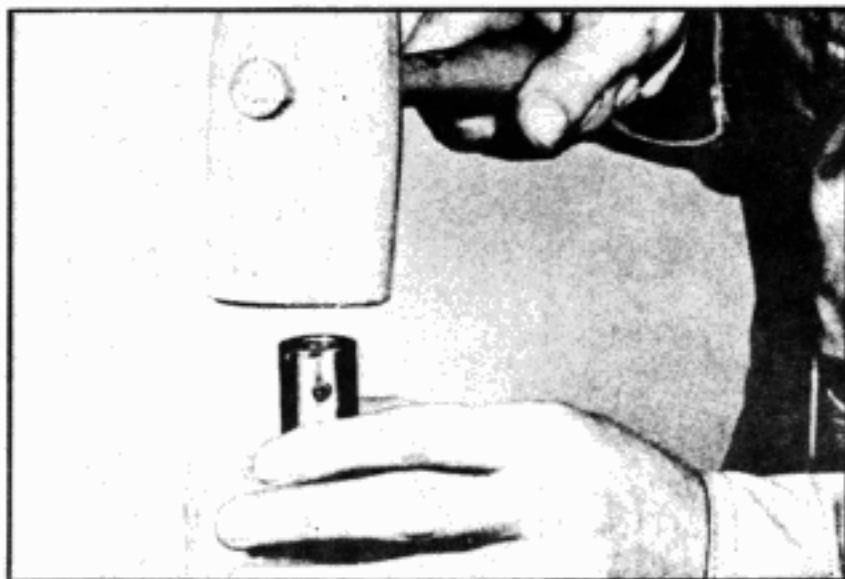

Fig. 70 Seating drive center with mallet

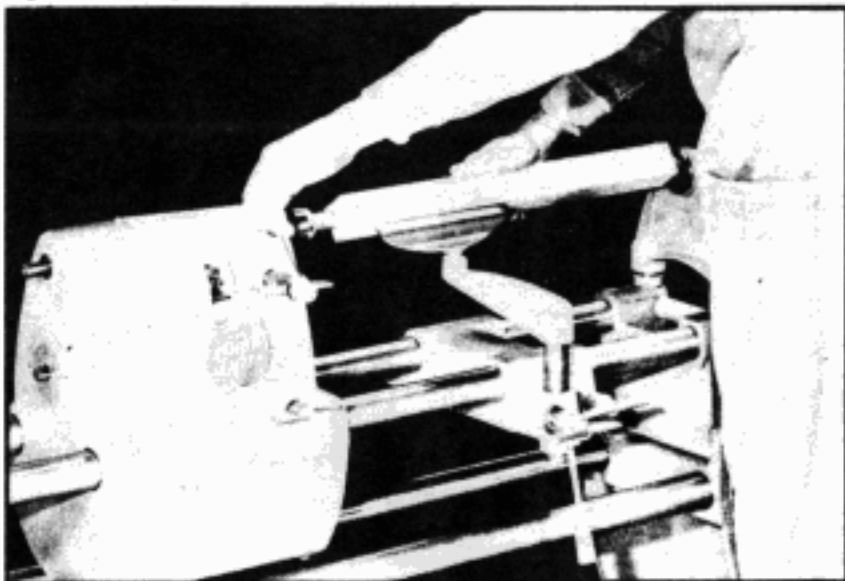

Fig. 71 Extending quill to mount spindle work

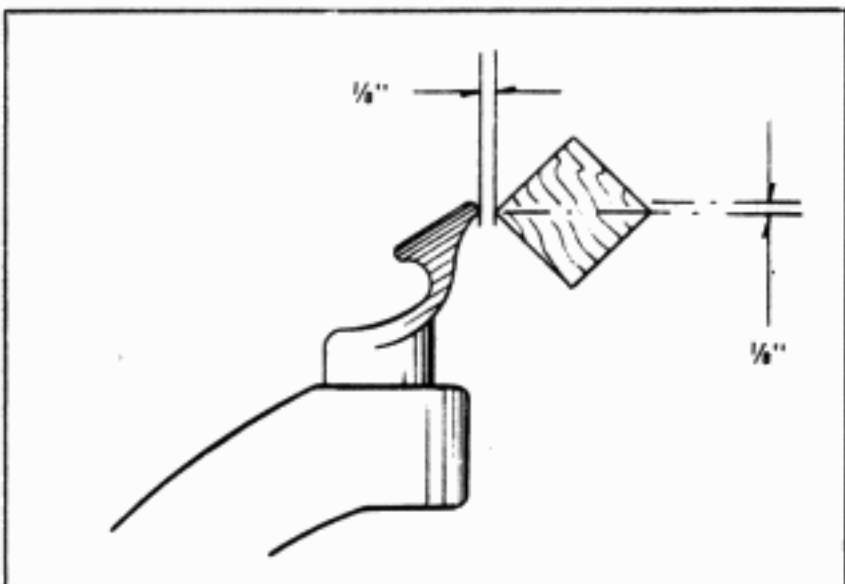

Fig. 72 How to adjust tool rest

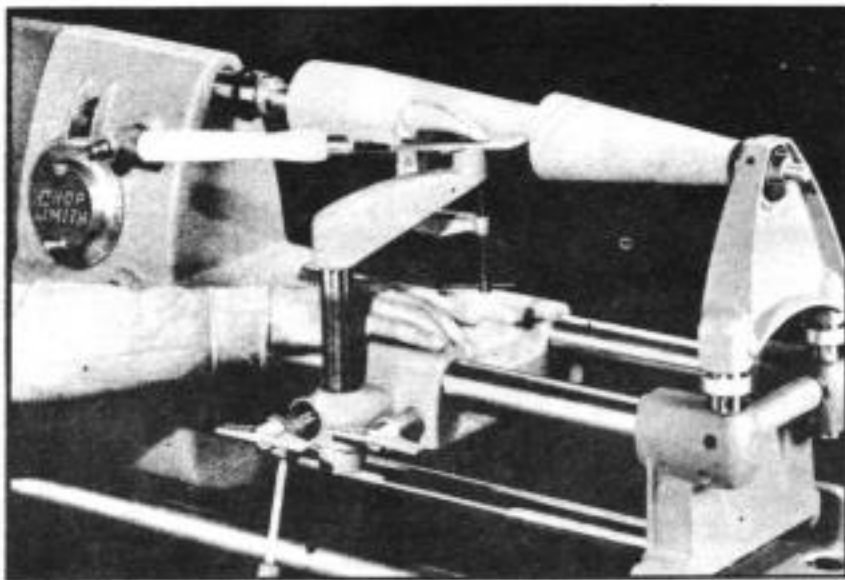

Fig. 73 Accurate tapers are easy on SHOPSMITH M5

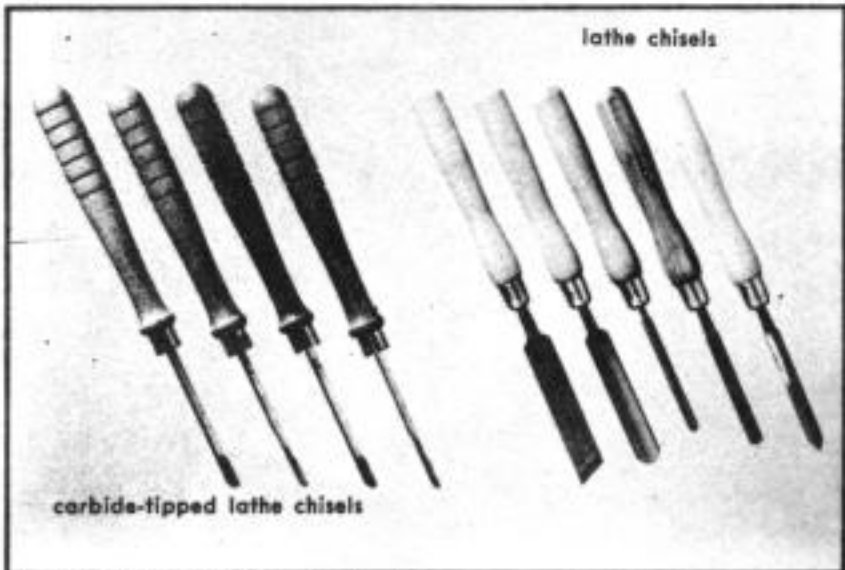

Fig. 74 SHOPSMITH lathe turning tools

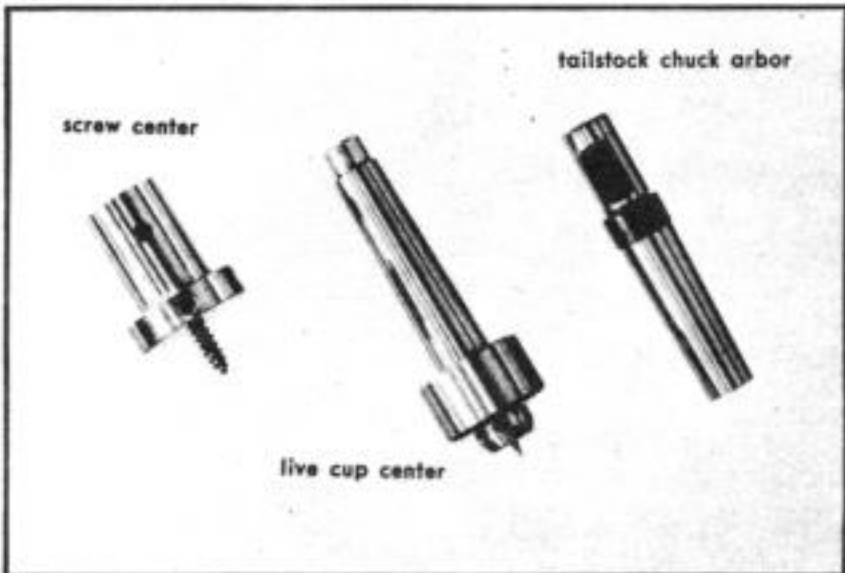

Fig. 75 Other lathe accessories

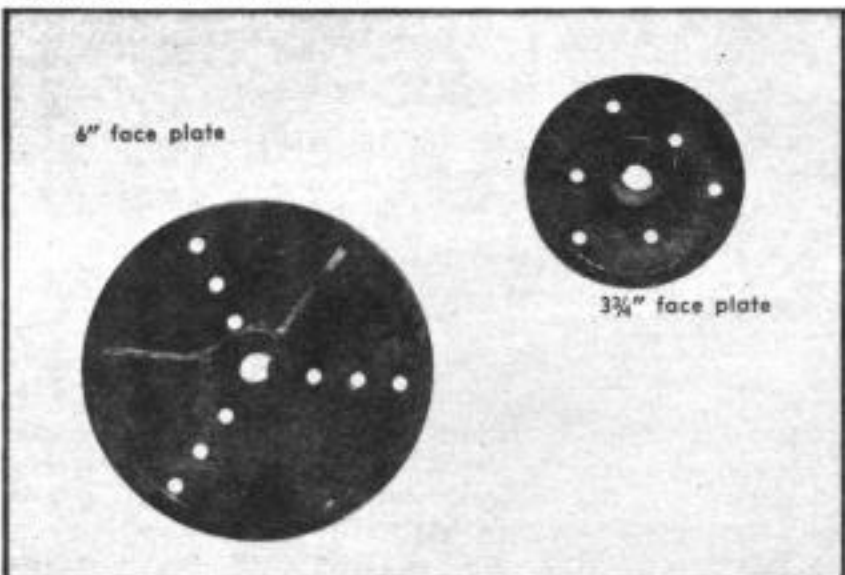

Fig. 76 SHOPSMITH face plates

Clamp the turning tool (the skew will do a good job) to the top of the tool rest arm (Fig. 73) and situate for a light cut. Turn on the machine and advance the tool slowly by sliding the carriage toward the tailstock. Move the carriage slowly and make successive passes until the taper is complete. Smooth with sandpaper as you would any other turning.

## Lathe Accessories

### Turning Tools

SHOPSMITH lathe chisels are high quality turning tools and are provided in an assortment that affords maximum utility and flexibility. The lathe chisels are packed in sets of five and include:

**3/4" gouge . . . .** For roughing stock from square to round and for preliminary dimensional shaping. Also good for cove cutting.

**1/4" gouge . . . .** For light roughing cuts, dimensional shaping and smaller cove cuts.

**1" skew . . . .** For smoothing and finishing surfaces, trimming cuts on ends and shoulders and for V-cuts.

**1/2" parting tool . . . .** Used mostly for dimensional cuts to determine cylinder diameters. Also useful for touching up and cleaning corners and shoulders.

**1/2" round nose . . . .** All-around tool for inside and outside contours. For hollowing, coving, circular grooving and general stock removal.

**Carbide tipped lathe chisels** are essential for any kind of free hand turning of non-ferrous metals, plastics and other non-wood materials. Also excellent for wood turning. Carbide chisels hold a sharp edge for a long time.

**Special bearing mounted cup center** turns with the stock and prevents burn marks. An essential tool for any kind of metal spinning. Differs from ordinary live centers in that it is specially designed for the woodworker.

The **screw center** is needed for mounting stock that is too small to be mounted between centers or on a face plate. Work is screwed on and turned like any other job.

The **tailstock chuck arbor** makes it possible to mount the Jacobs chuck in the tailstock for concentric drilling of stock which is mounted at the drive end. Good for lamp bases, candle sockets and useful for starting hollowing operations in bowls and similar projects.

SHOPSMITH **face plates** are available in 3 3/4" and 6" sizes. These are needed for mounting stock which is not held between centers. Bowls, bases for lamps, circular trays and similar projects are face-plate mounted for turning.

# The Disc Sander

1. **12" sanding disc** . . . . Affords 113 square inches of sanding area. Attaches directly to main or upper auxiliary spindle.
2. **Miter gauge** . . . . Used as stop or guide for many sanding operations. Use with rip fence to create jigs for duplicate sanding and special operations.
3. **Quill feed lever** . . . . Permits advancing disc into work. Unparalleled accuracy for single or duplicate parts because amount of work sanded off can be mechanically controlled with the feed stop.

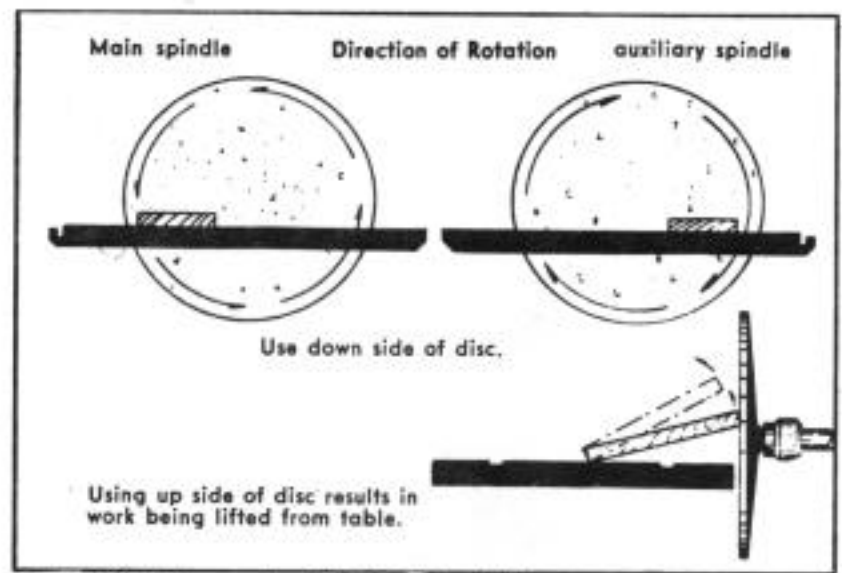

Fig. 79 Work placement relative to disc rotation

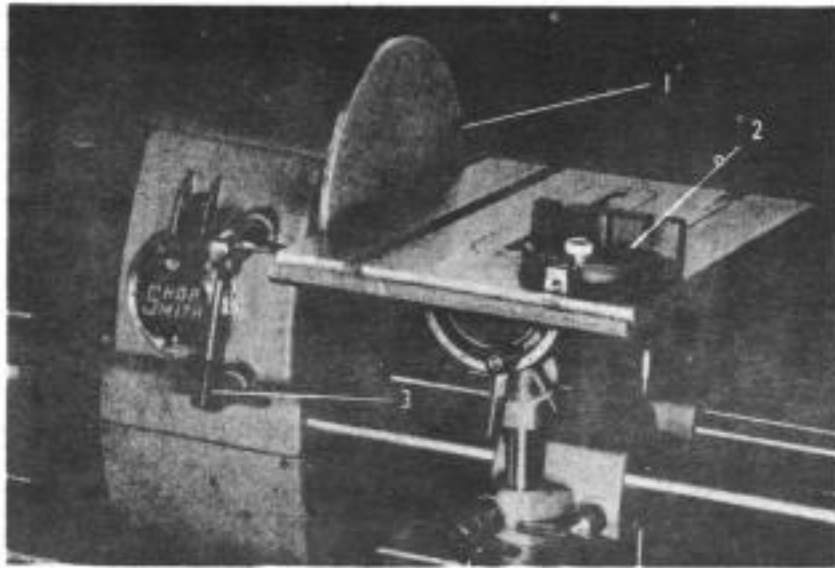

Fig. 77 SHOPS MITH M5 disc sander

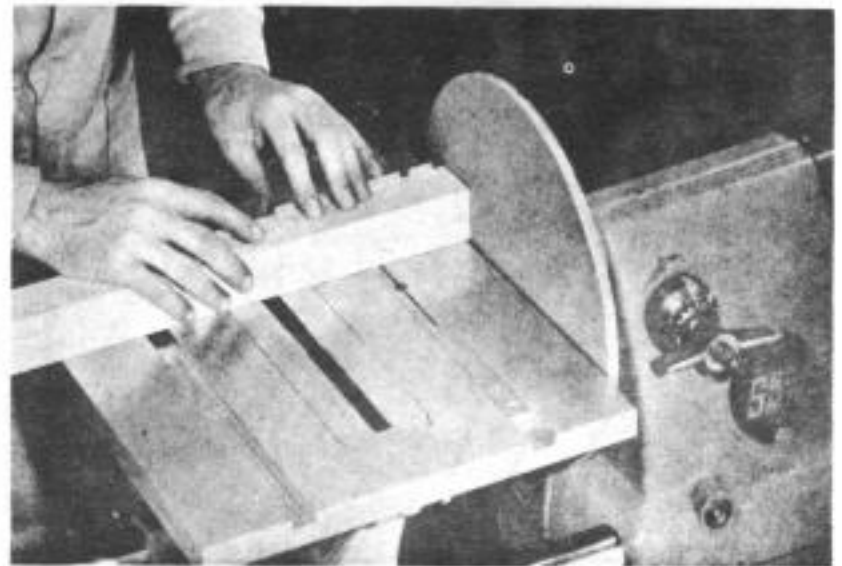

Fig. 80 Locked miter gauge is guide for end sanding

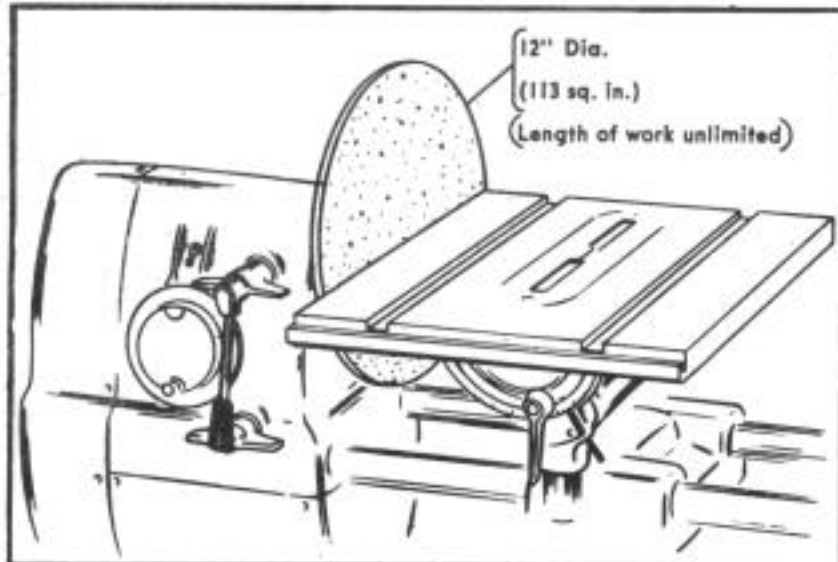

Fig. 78 SHOPS MITH M5 disc sander capacities

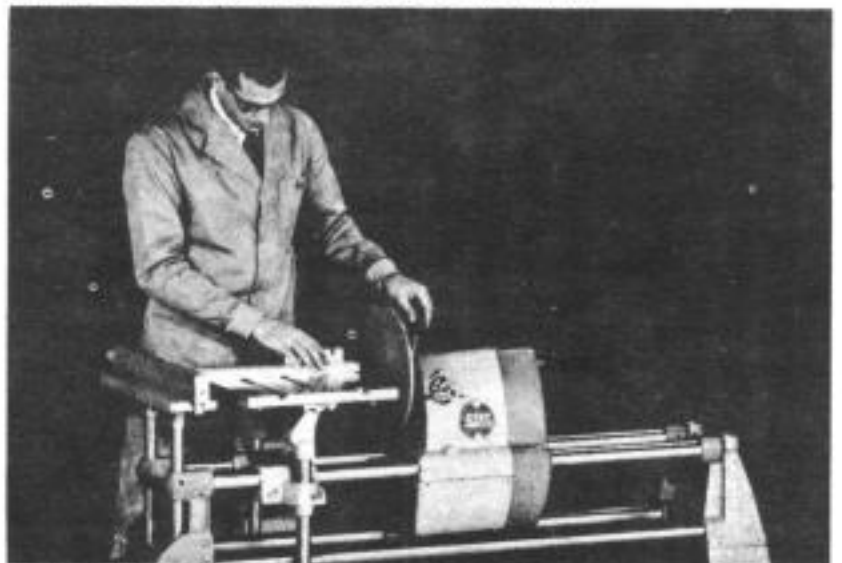

Fig. 81 Quill feeding disc for sanding to length

## How to Use the Disc Sander

### Attaching Sandpaper

Distic is applied to the disc while it is in motion. Since heat softens the adhesive it is best to warm the blank disc by holding a piece of wood against it while it is turning. After a few seconds apply the Distic by holding it firmly at the outer edge of the disc and then moving it slowly toward the center while the disc is turning. There should be an ample and uniform coverage, free of bumps. Apply the sandpaper sheet immediately. Never stand in line with the disc.

### Direction of Rotation

Sanding is always done on the down side of the disc (Fig. 79). If it is ever necessary to use the right hand side of the table, or if you are moving a long piece across the face of the disc, be sure to hold the work firmly down on the table to prevent the disc from lifting it.

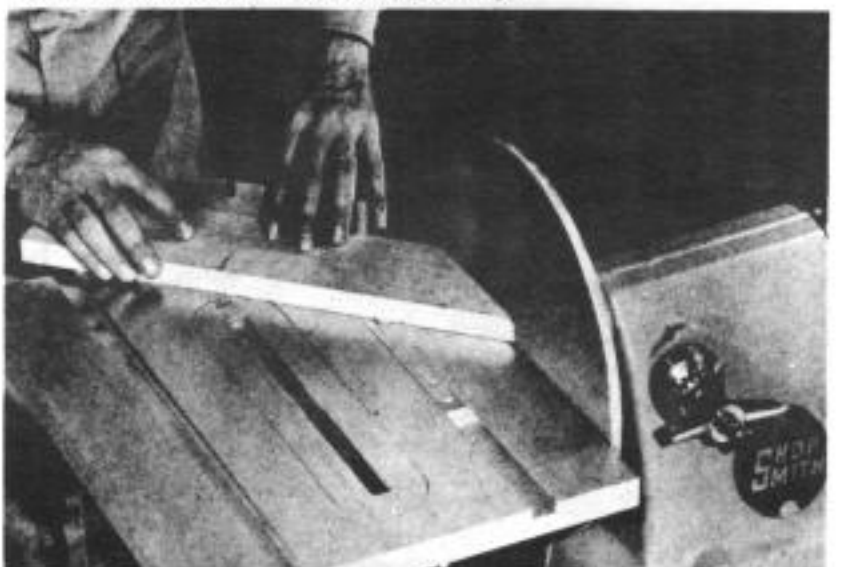

Fig. 82 Locked miter gauge is guide for miter sanding

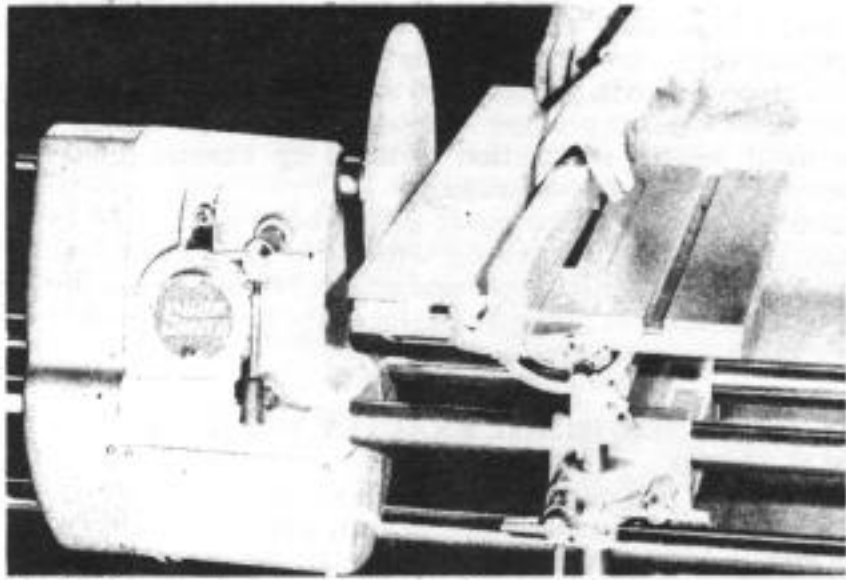

Fig. 83 Edge sanding plywood between disc and fence

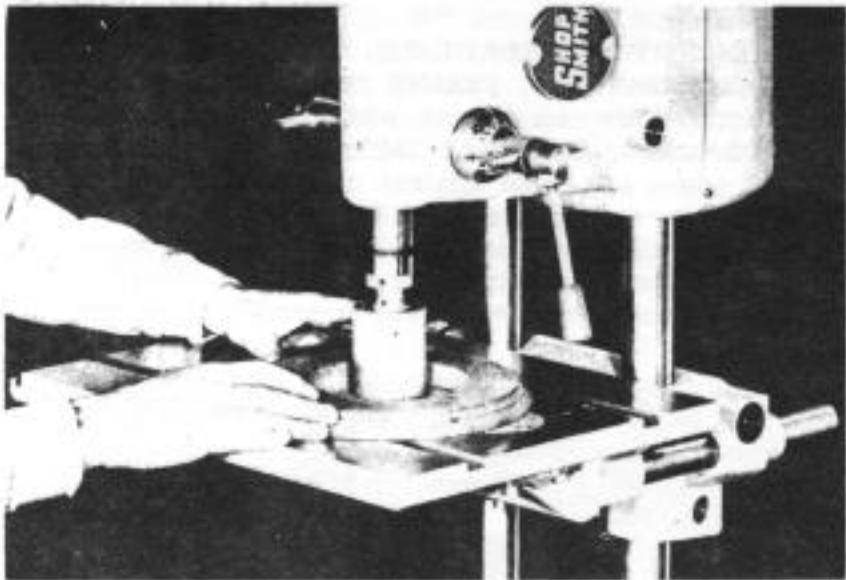

Fig. 84 Using shaper insert with drum sander

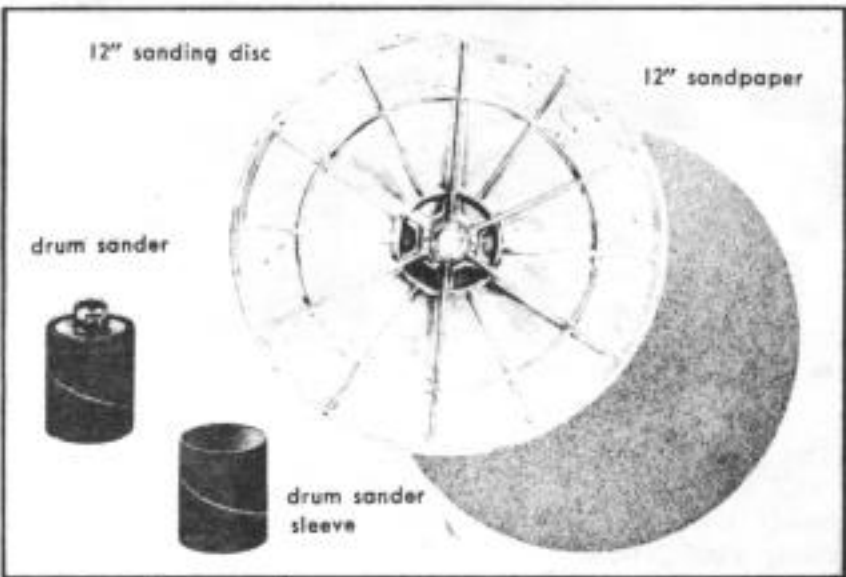

Fig. 85 Sanding accessories

## Sanding

Hold the work flat on the table and move it into the turning disc, or quill-feed the disc into the work. Whenever possible use the miter gauge as a guide. Curved edges are revolved in a sweeping motion. Feed should be light and smooth, even when a great deal of material must be removed. It is better to touch the work to the disc several times than it is to force it against the disc and hold it there. Burned edges, clogged paper and errors are avoided by working slowly and surely.

## End Sanding

Nothing does a crossgrain smoothing job like the disc sander, and SHOPSMITH is designed to further this end. Lock the miter gauge in place and use it as a guide to square the work to the disc (Fig. 80). The work may be advanced into the disc or it may be grasped firmly against the miter gauge head and the disc fed into it.

## Sanding to Length

Duplicate pieces are quickly and easily sanded to exact length by the following method (Fig. 81). Lock the table about  $\frac{1}{2}$ " away from the disc. Set the rip fence on the table or extension table, depending on length of work. Lock miter gauge in place to act as a guide for the work. Place one workpiece on the table and sand to the exact length required by feeding the disc into it. Turn off machine and extend disc to butt against sanded piece. Set depth control dial and lock the feed stop. Then sand each piece by placing in jig formed by miter gauge and rip fence and feeding disc forward. **FEED SLOWLY—NEVER FORCE THE DISC INTO THE WORK.**

## Miter Sanding

The best way to get perfect miters is to saw the pieces about  $\frac{1}{16}$ " oversize and sand them to exact length (Fig. 82). Lock the miter gauge in place after it has been set to the angle needed. Place and hold the work firmly against the miter gauge and feed the disc forward.

## Angular Sanding

For bevels and cross miters tilt the table to the angle needed and sand as you would any other piece. Always tilt the table to form an open angle with the disc. If you tilt the other way there is the possibility, especially with thin pieces, that the work will grab between the edge of the table and the disc.

To sand compound angles set the miter gauge and table to the same angles used to cut the pieces on the saw.

## Jointing on Disc Sander

Long, straight edges are sanded smooth and square in an operation that combines sanding, jointing and finishing to exact width (Fig. 83). Use the off-set screw to set the rip fence at a slight angle to the disc. The distance from fence to disc should be slightly less than the width of the workpiece. Angle of the fence should be such to allow contact from outer edge of the disc to just short of the center. Work is fed through *from the back* toward the front of the table while contact is maintained with the fence throughout the pass. As always, work slowly—do not force the cut. This setup is a very practical method of jointing plywood.

## Sanding Accessories

### Drum Sander

The drum will sand inside and outside curves and internal circular cutouts with a speed and efficiency impossible to achieve with other means (Fig. 84). The special shaper insert is used with the drum sander to give support in the area immediately surrounding the drum.

Sandpaper, in disc form for the disc sander and in sleeves for the drum, is available in coarse, medium and fine grits. It is a good idea to have a full and ample supply of each type and grit ready for immediate use at all times.

For maximum convenience it is advisable to have several sanding discs and drum sanders on hand so that different grit papers stand ready for immediate use.

## Adjustments

### Table

#### IF TABLE SLOTS ARE NOT PARALLEL TO SAW BLADE

Loosen four hex head cap screws which secure table to trunnion and to rear bracket. Do not loosen more than one full turn. Tap the table lightly with the heel of your hand to "rotate" it into correct alignment. Lock the four cap screws, turning each one a small amount, then repeat until each is secure.

#### IF TABLE, WITH TRUNNION SET AT "0," IS NOT EXACTLY 90 DEGREES TO SAW BLADE

Loosen table tilt lock and pull out trunnion plunger. Set table at exactly 90 degrees and secure table tilt lock. Push in plunger and turn Nylok set screw until it just bears against plunger. Adjust trunnion vernier plate until middle calibration is lined up exactly with "0" mark on trunnion.

Tilt table until middle calibration on trunnion vernier plate lines up exactly with 45 degree mark on trunnion. Lock table. Push in plunger and adjust Nylock set screw until it just bears against plunger.

### Miter Gauge

#### IF MITER GAUGE, AT 90 DEGREE SETTING, IS NOT EXACTLY SQUARE TO BLADE

Loosen lock knob and pull out miter gauge plunger. Adjust miter gauge head exactly square to blade and lock in place. Push in plunger and adjust Nylok set screw until it bears against plunger. Adjust miter gauge vernier plate until middle calibration is lined up exactly with 90 degree mark on miter gauge.

Loosen knob and turn miter gauge head until center vernier plate mark is lined up with 45 degree mark on miter gauge. Push in plunger and adjust Nylok set screw until it bears against plunger. Make a similar adjustment on the opposite 45 degree auto-stop.

### Rip Fence

#### IF RIP FENCE IS NOT EXACTLY PARALLEL TO TABLE SLOTS

Loosen the two cap screws which secure the fence to the base casting. Set the fence exactly parallel to either table slot and tighten the locking handle. Then retighten the two cap screws.

### Extension Table

#### IF IT IS NOT PARALLEL TO SAW TABLE AND IN LINE ACROSS THE FRONT SURFACE

Loosen the four cap screws which secure it to its mounting bracket. Push saw table against extension table until edges are flush against each other. Tap extension table forward or back until front edge is in line with front edge of saw table. Re-tighten four cap screws turning each a small amount until all four are secure.

## Major Accessories

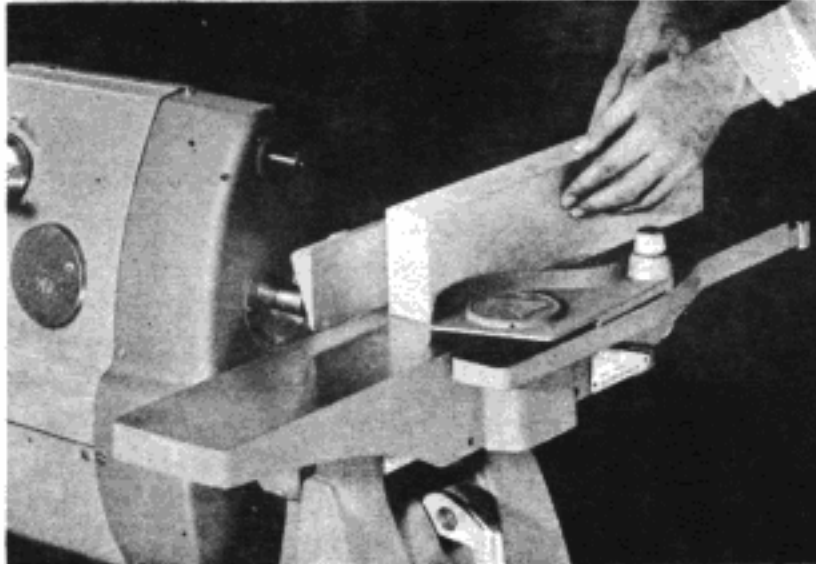

Fig. 87 Jointer on POWER MOUNT

The jointer (Fig. 87) is a mechanical planer that will cut edges square and smooth, do surfacing operations, cut rabbets and tenons, form tapers and recesses, and do beveling and chamfering jobs.

The Magna 4" jointer is not only ideally suited for dual-purpose mounting with the SHOPSMITH table saw, it is the most precise jointer available and one of the most convenient to use.

### Specifications

Width of cut.....	4"
Depth of cut.....	¾"
Rabbet cut.....	¾"
Over-all table length.....	28"
Fence.....	3" high by 21¾" long
Rabbeting ledge.....	2½"

Fence tilts 45 degrees left to 45 degrees right—has adjustable auto-stops at 45, 90 and 45 degree positions. The three knives are precision ground and have exclusive tapered form safety feature. Each knife is individually adjustable to fixed outfeed table, the easiest method yet devised for jointer knife adjustment.

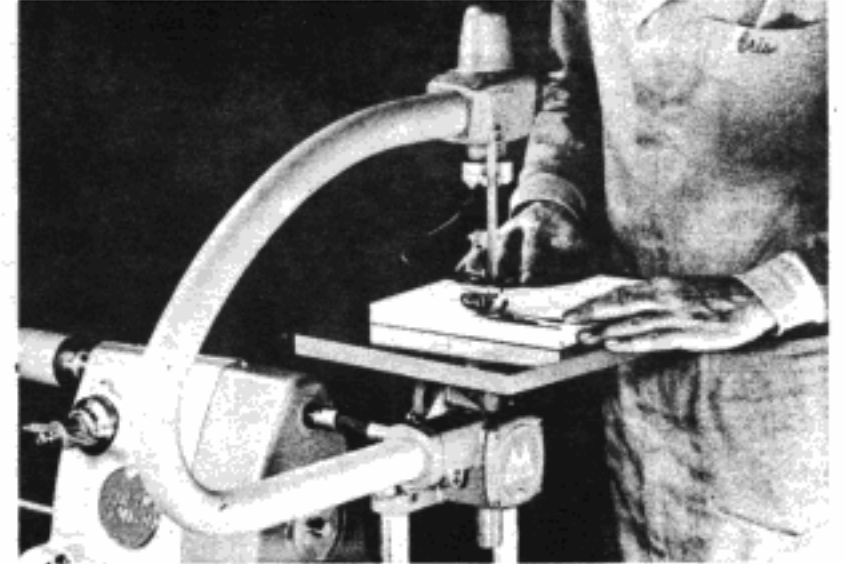

Fig. 88 Jigsaw on POWER MOUNT

The jigsaw is a "must" for cutting curved lines and for any kind of work requiring internal cutouts. It is probably the safest tool to use and ideally suited for teaching youngsters.

Like the jointer, the Magna jigsaw (Fig. 88) is a complete tool ready for mounting on SHOPSMITH in seconds. Twin tube mount is quick and easy. Flexible coupling power transmission through rear auxiliary spindle.

You have variable speeds because of SHOPSMITH'S exclusive SPEEDIAL. This means the correct speed for easy jigsaw operation, slow speeds for filing and sanding and really high speeds for safe, smooth cutting.

### Specifications

Cuts to center of.....	36" panel (no limit as saber saw)
Thickness of cut.....	2"
Length of stroke.....	¾"
Table size.....	11" x 11"
Table tilt.....	0-45 degrees
Blade length.....	5"

Has an automatic, built-in sawdust blower and adjustable blade tensioning device, hold downs and blade guides. Chucks index 90 degrees for cutting long stock.



## General Accessories

### Universal Hold Down

Adding the universal hold down (Fig. 89) to your shop equipment is like acquiring another pair of hands. The hold down is designed for use on the miter gauge, rip fence, shaper fence or any side of the table in vertical or horizontal position. It will hold the work securely against the fence and table close to the cutting tool, thereby keeping hands out of danger zones. Prevents chatter by holding the work firmly during shaping, molding, routing and even some simple sawing operations. Long mounting bars allow maximum adjustment in thickness and width of work. Excellent for miter cuts and for holding odd-shaped pieces.

### Retractable Casters

Retractable casters (Fig. 90) are easily installed on SHOPSMITH pre-punched bench ends. Foot activated, revolving star wheel raises or lowers machine immediately. Raise machine for mobility, lower when machine is used. Permits use of SHOPSMITH anywhere in or outside the house or shop.

### Safety Goggles

Comfortable, impact resistant, safety goggles (Fig. 91) should be used on all abrading procedures and any operation that throws off chips and grit. A small investment—a big dividend in eye protection. These goggles will fit over glasses. Used in many industrial plants.

### Safety Switch and Outlet Box

Compact unit, easily mounted under SHOPSMITH M5 base plate (Fig. 92). SHOPSMITH motor lead connects to box. Lead from box goes to power source. Extra outlet provided. Machine cannot be turned on without special key. Key switch is used merely to supply or cut off the power. Regular headstock switch is used to turn the machine on or off during use.

### SHOPSMITH Cover

Heavy cover protects SHOPSMITH against dirt and dust when not in use. Box design provides efficient coverage.

### Magna Lube

Special grease for SHOPSMITH drive sleeve, spindle spline and quill rack teeth. Specially designed for SHOPSMITH by Standard Oil Company of California.

### Rust Preventive Spray

May be used on any machine or tool that requires protection from rust. You merely spray it on.

### Power Tool Woodworking for Everyone

The famous SHOPSMITH book. Hailed by all people who use power tools as the best book in the field. Reduces basic and advanced woodworking techniques to simple, step-by-step instructions that are easily followed even by the beginner. Over 700 photographs and drawings SHOW you what to do and HOW to do it.

Written by one of the country's top how-to-do-it specialists, R. J. DeCristoforo. A wonderful book for anyone interested in working with power tools—especially useful for SHOPSMITH owners.

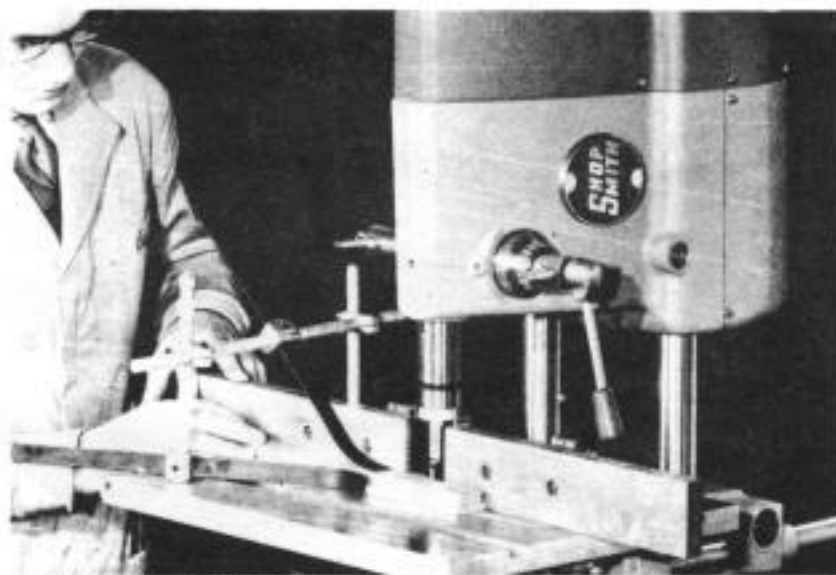

Fig. 89 Universal hold down on shaper fence



Fig. 90 Retractable casters

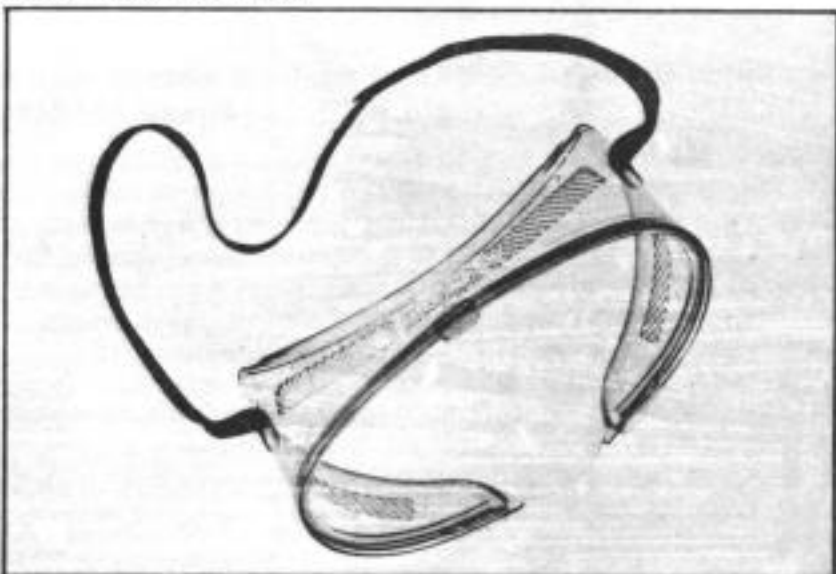

Fig. 91 Safety goggles

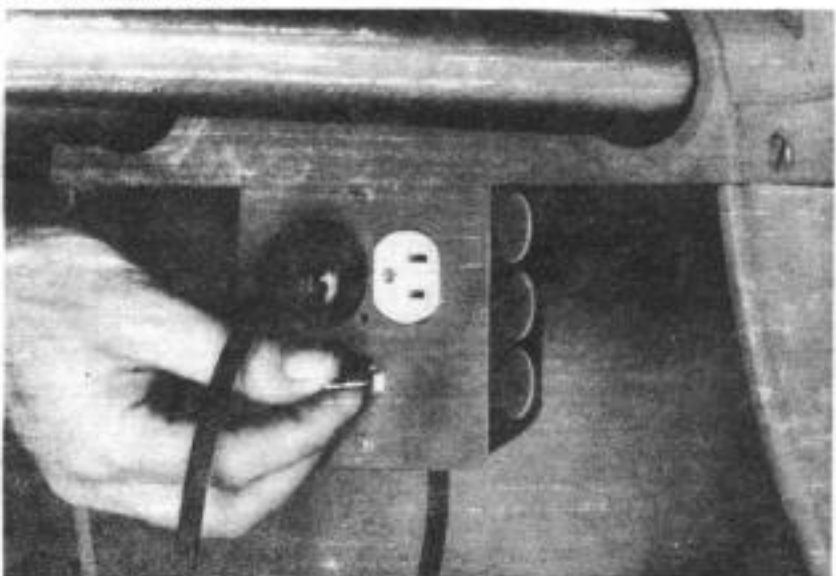
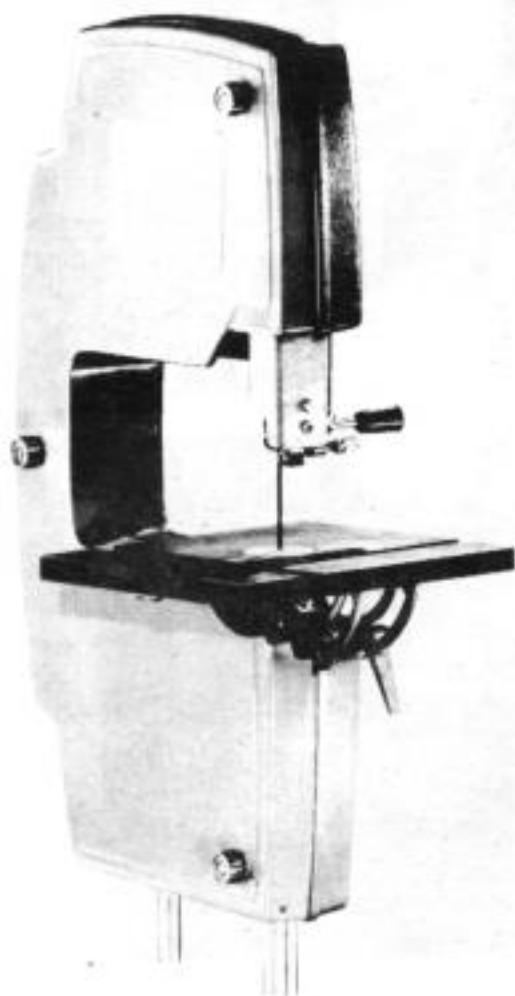

Fig. 92 Safety switch and outlet box



**Eleven-inch Bandsaw 505641**

For precision cutting of curved, irregular, or straight lines. Handles any job from tough sawing of 6" thick stock to most intricate scrollwork—with extra-quick blade change between! If you need cut-off capacity of more than 11", the blade can easily be offset—then cut-off capacity becomes unlimited! Big 11 3/4" x 12" tilting table gives proper support for sawing of even large-size work pieces. Special table slots permit use of Shopsmith locking miter gauge and pistol grip hold-down accessory, for top accuracy in ripping or cross-cutting, plus greater safety when working smaller pieces.

**Specifications**

- Cutoff Capacity (blade normal) . . . 10 1/2"
- Cutoff Capacity (blade offset) . . . Unlimited
- Depth of Cut . . . 6"
- Table Size . . . 11 3/4" by 12"
- Table Tilt . . . 5° left — 45° right
- Auto Stop . . . at "0"
- Bearings . . . Sealed, double ball and 2 needle
- Speeds . . . 700 to 1100 RPM
- Blade Tension . . . Built in scale
- Takes Blades . . . 1/8" to 1/2"
- Blade Tracking . . . Automatic
- Motor . . . None for Shopsmith 1/2 or 3/4, 1725 RPM on stands
- Weight . . . 45 lbs.
- Other . . . Double slots in table for miter gauge
- Features . . .

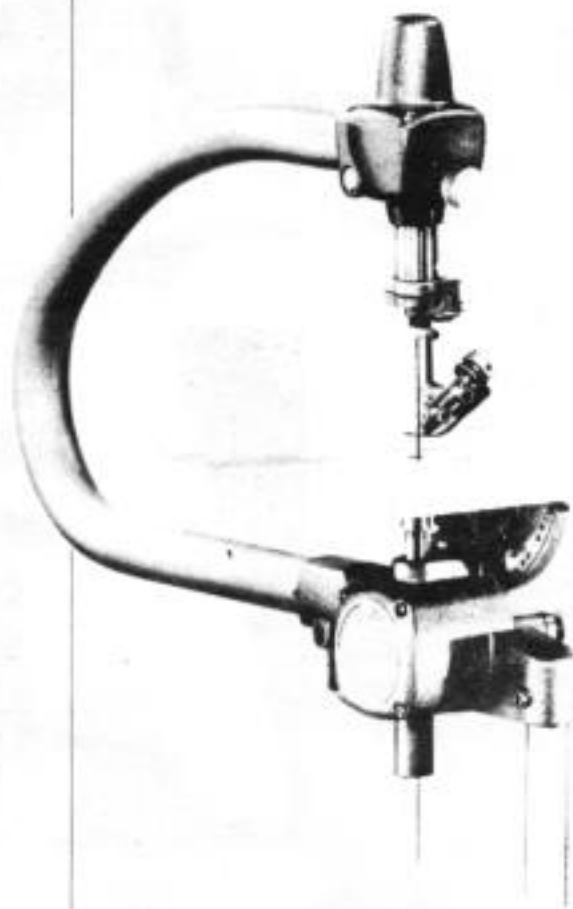

**Eighteen-inch Variable Speed Jigsaw 505644**

Actually a jigsaw and sabre saw in one! Utilizes the "built-in" power of Shopsmith 1 1/2 h.p. motor and Speed-Dial that lets you select exactly the right speed for every kind of blade and material—wood, plastic, metal, even cardboard! 2" thickness capacity; cuts to center of a 36" panel. Table tilts from 0 to 45°, with automatic stops. Other features include built-in blower, adjustable blade guides, work-piece hold-down, adjustable tensioning for light and heavy blades. Tubular arm pivots to position below table for use as a sabre saw and filing machine. For use with Shopsmith only.

**Specifications**

- Capacity . . . . . Cuts to center of 36" panel—full 18" throat
- Depth of Cut . . . 2" as jigsaw, more as saber saw
- Maximum Speed . . . 2500 RPM
- Table Size . . . 11" by 11"
- Table Tilt . . . 0 to 45° with automatic stops
- Motor . . . None on Shopsmith. 1/2 or 3/4 H.P. for use on power stands
- Weight . . . 29 lbs.



**Compressor-Sprayer 505643**

Applies the last "professional" touch—smooth, uniform coats of paint, varnish, lacquer, or wood-finishing stains. Paint inside or outside your house, thanks to special couplings that let you add up to 100 feet of regular garden hose, for a total range of 115 feet! Features diaphragm-type compressor, one-quart metal container, 15' hose, dual-purpose bleeder gun, choice of syphon or pressure feed, and spray heads for external or internal mix. Plus a dusting nozzle—even a tire inflator! And, sealed ball bearings never require oiling—assure dependable operation, job after job!

**Specifications**

- Displacement . . . . . 4 cu. ft./min.
- Air Delivery . . . 2.4 cu. ft./min.
- Working pressure . . . 30 pounds
- Spray Heads . . . Both external and internal mix
- Feed . . . Both pressure and feed
- Motor . . . None on Shopsmith or Sawsmith. 1/2 or 3/4 for use on power stands.
- Weight . . . 13 lbs.
- Other . . . Can be operated as far as 115 feet from motor
- Features . . .

**For information on stands and motors available for mounting Add-A-Tool Major Accessories independently of Shopsmith or Sawsmith, see the back page of this catalog.**

## To make your Shopsmith or Sawsmith even more versatile—Add-A-Tool!

5 major Add-A-Tool Accessories mount on your Shopsmith or Sawsmith in seconds—and no individual motors are necessary!

Exclusive Power Mount on the Shopsmith, or special Add-A-Tool bracket for Sawsmith, lets you utilize the powerful 1½ h.p. variable-speed drive that develops over 2 h.p. You dial the exact speed you need for perfect sawing, jointing, sanding, painting and finishing!

No separate stands required! But if you wish, Add-A-Tool Accessories can be set up separately. And they store away neatly on the wall.

Add-A-Tool Accessories are rugged, industrial-quality equipment—at far less than industrial prices! Thanks to unique product design and precise engineering, each Add-A-Tool combines high-performance features with the kind of durability that leads to years of trouble-free operation. All that, plus a moderate pricetag, makes each Add-A-Tool a truly outstanding value.

So to do the job right—with ease, speed, accuracy every time—Add-A-Tool! Features, functions and specifications of the 5 Major Accessories are shown at the right.

### Go wherever you want in the world of craftsmanship with Shopsmith and Sawsmith accessories!

The low-cost, high-quality accessories shown in this catalog extend the capability of your Shopsmith and Sawsmith to an almost unlimited range.

Engineered and manufactured by power tool experts, these accessories let you tackle virtually any woodworking operation—plus plastic and metalwork, too.

Most can be used with all power tools, though a few are designed exclusively for Shopsmith and Sawsmith. So browse the pages of this catalog—you'll find the accessories that will enhance your skill and help you successfully complete whatever project you plan.

## The Shopsmith Guarantee

The Shopsmith, the Sawsmith, and all Add-A-Tool Major Accessories are unconditionally guaranteed against defects in material and workmanship. This guarantee extends for one full year from date of purchase provided the warranty card accompanying the product is signed and returned to us.

During the warranty period, any repairs or parts replacement necessitated by defects in material or workmanship will be made at no cost.

Shipping costs to and from our authorized service center or factory will be assumed by the owner.

Shopsmith, Inc.

# Shopsmith add-a-tools Shopsmith

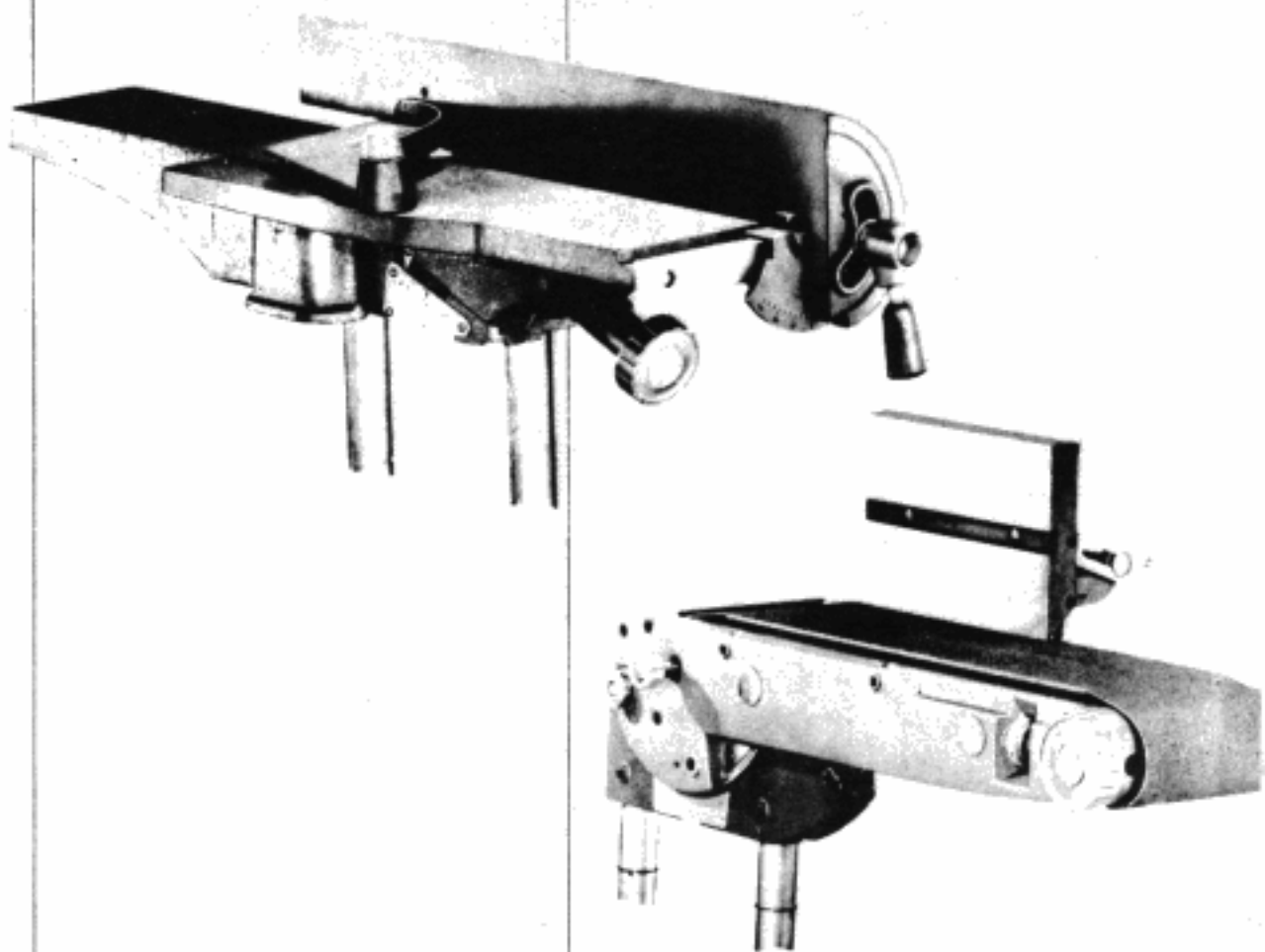

### Four-inch Jointer 505681

Extra-capacity heavy-duty unit lets you handle big jobs with maximum safety and support. Make joint cuts up to 4" wide, rabbit cuts up to 2½" wide—and both to a depth of ¾"! Table measures 28" long, fence 21¾" x 3". Cast iron construction of each is designed to stand up under the continued battering of heavy shop use. Fence includes adjustable auto-stops at 45 degrees left tilt, 90 degrees, and 45 degrees right tilt. Jointer also features adjustable safety guard, single-knob control of table set and tilt, plus easy-view depth-of-cut scale to eliminate the need for measuring. Cutting blades run on ball bearings lubricated for life, to assure low maintenance, years of accuracy. All surfaces are precision-ground for true accurate surfacing.

#### Specifications

Width of cut . . . 4"  
 Depth of cut . . . ¾"  
 Table length . . . 28"  
 Fence . . . . . 21¾" by 3"  
 Depth of Rabbit Cut . . . ¾"  
 Width of Rabbit Ledge . . . 2½"  
 Fence tilt . . . . . 0 to 45° right or left adjustable stops  
 Motor . . . . . None for Shopsmith or Sawsmith. ½ or ¾ H.P. for use on stands.  
 Weight . . . . . 53 lbs.

### Six-inch Belt Sander 505642

Put a satin-smooth surface on your woodworking projects—and eliminate hours of tedious hand sanding! This heavy-duty 6" unit operates in infinite positions from horizontal to vertical on Shopsmith's Power Mount. Big 6" x 9" table mounts across the belt, parallel to the belt, or at an angle to it—giving you straight-line sanding accuracy, no matter what the size or shape of your work piece. Single large tensing handle lets you put Auto-Tension on the belt, to change belts in seconds without disturbing belt tension. Slack drum on rear of unit permits easy sanding of irregular shapes and there is an auxiliary spindle for drum or disc sander, wire brush, etc.

#### Specifications

Belt Size . . . . . 6" by 48"  
 Table Size . . . . . 6" by 9"  
 Back up . . . . . 6" x 16½" plate  
 14" above table  
 Bearings . . . . . Sealed ball on drive, oil on idler  
 Drums . . . . . 3" diameter  
 Drive drum rubber covered  
 Table Tilt . . . . . 0 to 20° into belt, 45° away from belt  
 Range . . . . .  
 Speed range . . . 1150 to 2000 RPM  
 Motor . . . . . None required on Shopsmith or Sawsmith. ½ or ¾ H.P. for use on stands  
 Weight . . . . . 36 lbs.  
 Other . . . . . Belt Sander operates in any position from horizontal to vertical  
 Features . . . . .



### Arbors

Precision manufactured from fine tool steel for interchangeable use on Shopsmith, Sawsmith and other power tools. No. 505511 is for Shopsmith and No. 505512 is for Sawsmith, using 1 1/4" bore saw blades. The others can be used for saw blades, grinding wheels, wire brushes, dado sets, etc., on all power tools. Having tools mounted on extra arbors, ready to slip onto the tool spindle, saves time and trouble in any shop. Universal Arbors include a special keyed washer to allow safe use on right or left-hand rotating shafts.

- 505505—1/2" Universal Arbor
- 505506—3/8" Universal Arbor
- 505511—1 1/4" Saw Arbor (Shopsmith)
- 505512—1 1/4" Saw Arbor (Sawsmith)

### Allen Wrench

Extra long to provide easy access to all set-screws on Shopsmith, Sawsmith and accessories. Precision made for standard hex-socket screws and carefully hardened.

- 505516—5/32" Allen Wrench



### Shopsmith Precision Dado

Exclusive, patented tool cuts an infinite range of grooves and dados from 1/32" to 3/8" wide, up to two inches deep. Extremely handy for rabbeting and tenoning. Width of cut is controlled by gear-synchronized hub with can-action design simply with an Allen wrench (included). For real convenience, width can be adjusted without removal of blade from the spindle. Heavy 8" blade is 1/8" thick with special tooth design to assure smooth, precision cut; blade is hard chrome plated to resist corrosion. Fits all saws with 5/8" or 3/4" arbors. With Shopsmith, use "Table Insert-Dado" (505621)

- 505514—Shopsmith Precision Dado

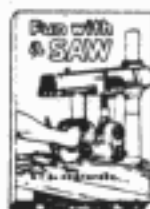

### Shopsmith Publications

Up-to-date, comprehensive, authoritative books on power tool operation, furniture crafting and other woodworking projects. Describing professional techniques, these books enable almost anyone to perform expertly on jobs in his own home. Profusely illustrated and written by the noted woodworking author, Mr. R. J. DeCristoforo, in simple, easy-to-follow style... no matter what tools you have. "Power Tool Woodworking for Everyone" is particularly for the Shopsmith enthusiast and "Fun with a Saw" for all radial arm saw wood workers.

- 505507—Power Tool Woodworking for Everyone (340 pages)
- 505519—Fun with a Saw (216 pages)

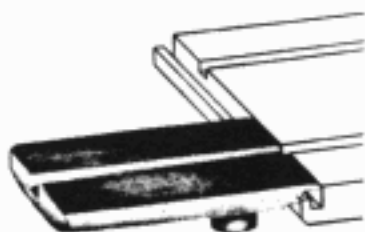

### Front Table Extension

Increases table by 7" in front of saw blade for support of extra wide pieces. Attaches anywhere on front of table or extension table with a single twist of knob.

- 505626—Front Table Extension

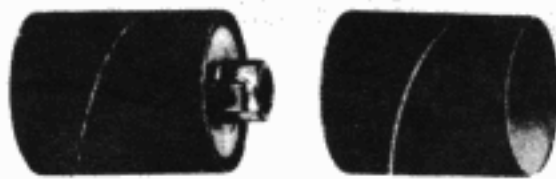

### Drum Sander

2 1/4" diameter is perfect for fast contour sanding of all sorts of shapes: can be used in vertical or horizontal position. Use either with Shopsmith Shaper Fence or Sawsmith table fence for precise edge sanding (with Shopsmith, use Table Insert, Shaper & Drum Sander 505509). Can be used with other tools. Abrasive sleeves locked firmly in place by rubber expansion cylinder. Can be used on 6" Add-A-Tool Belt Sander.

- 505552—Drum Sander

### Drum Sander Sleeves

Long-wearing, fast-cutting garnet abrasive, an industrial type sanding paper well known for its excellent performance on all sorts of sanding. In ready-to-use sleeves for 2 1/4" diameter sanding drum, 3" wide.

- 505531—Assorted (pkg. of 6)
- 505532—Coarse (pkg. of 6)
- 505533—Medium (pkg. of 6)
- 505682—Fine (pkg. of 6)



### Liquid Adhesive

For quick, easy application of paper discs. Easy to apply, dries rapidly; positively locks paper to disc yet permits easy, complete removal.

- 505554—Liquid Adhesive (1/2 pint)

### Pattern Maker's Glue

Perfected after years of research and testing in professional pattern shops. Truly a perfect woodworking glue, available for the first time to home shops. Packed in 8 oz. plastic, self-dispensing container. Quick-drying, water-resistant.

- 505537—Pattern Maker's Glue

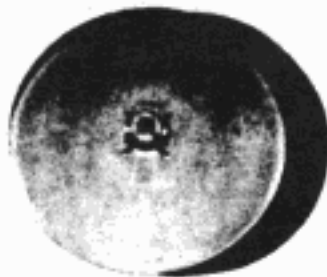

### Sanding Discs

Lightweight, yet rugged aluminum casting precision balanced to run smoothly. Useful for all tools and motors for rapid sanding. Complete shops have a separate disc for each grade of sanding paper, allowing instant changeover.

- 505551—12" Sanding Disc
- 505550—10" Sanding Disc
- 505549—9" Sanding Disc

### Sandpaper Discs

Precisely cut to fit 12", 10", or 9" sanding discs this paper is industrial type paper with long-wearing, fast-working garnet abrasive.

Pkgs. of Six Assorted	Coarse	Medium	Fine
12" Paper	505523	505524	505525
10" Paper	505501	505502	505503
9" Paper	505527	505528	505529

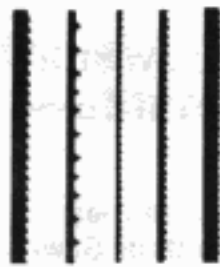

### Jigsaw and Sabre Saw Blades

5 different types of oil-hardened, tempered steel blades. For scroll and intricate design cutting of wood, plastics, non-ferrous metal and other similar material.

#### Packages of 6:

- 505667—1/4" wide, coarse tooth—Best for soft and hardwood, pressed wood.
- 505668—110" wide, medium tooth—Best for metals, wood, felt, paper.
- 505669—070" wide, medium tooth—Best for wood, plastics, hard rubber.
- 505670—110" wide, fine tooth—Best for aluminum, copper, mild steel, 1/16" to 1/8" thick.
- 505671—1/4" wide, fine tooth—Best for aluminum, copper, mild steel, 1/16" to 1/2" thick.



### Lathe Chisel Set

Special set of 5 most widely used lathe chisels for all lathe operations. Chisels are of finest alloy steel to hold a sharp cutting edge longer. Handles are hard rock maple, proportioned and shaped for fine balance. Set includes 1" skew, 1" gouge, 1/2" parting tool, 1/2" round nose and 3/8" gouge.

- 505586—Lathe Chisel Set (5)

### Carbide Lathe Chisels

Retain their razor-sharp edge indefinitely—tungsten carbide tip; can be used for free hand turning of soft metals as well as plastics and wood. The three most popular sizes:

- 505587—1/8" Square Nose
- 505588—1/4" Square Nose
- 505589—1/4" Round Nose



### Saw Guard

Single unit covers upper and lower portions of saw blade with no limitation of Shopsmith versatility. Upper guard adjusts automatically to thickness of stock; splitter keeps kerf from closing on saw blade; anti-kick-back fingers grip stock firmly without marring surface. Lower guard channels sawdust away from operator—for Mark VII, into the sawdust vacuum. AN IMPORTANT ACCESSORY FOR SAFETY. Must be used as a pair—do not order separately.

- 505627—Saw Guard, Upper/ Splitter (Attaches to 505705)

- 505705—Sawdust Chute and Under Table Guard

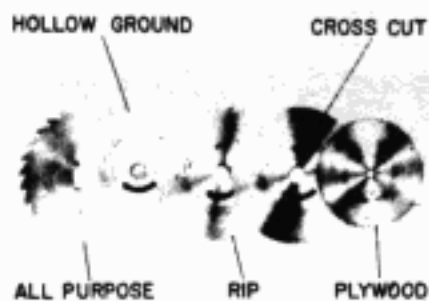

### Saw Blades

A blade for every purpose is the mark of the craftsman. Having the blades mounted on arbors for instant changing makes it easy to use the right blade for clean, easy cutting and professional results. All blades are hard chrome plated to resist corrosion, permit blade to develop full power. All-purpose blade is standard replacement; use hollow-ground blades for precision work and smooth cuts; cross-cut and rip blades are most efficient for operations indicated; plywood blades make smooth, splinter-free cuts. (Dimension indicates bore and arbor needed.)

### 8" Blades

- 505538—Plywood (3/8")
- 505543—Plywood (1/4")

### 9" Blades

- 505539—All-purpose (1/4")
- 505540—Hollow-ground (1/4")
- 505541—Cross-Cut (1/4")
- 505542—Rip (1/4")

### 10" Blades

- 505544—All-purpose (1/4")
- 505545—Cross-Cut (1/4")
- 505546—Rip (1/4")
- 505547—Hollow Ground (1/4")



### Sanding Belts

Popular 6" by 48" size sanding belts for the Add-A-Tool-Belt Sander and many others. Fabric-backed belts in three grades of open grain garnet abrasive for long wear and fast cutting.

- 505534—6" Sander Belt—Fine
- 505520—Fine (Factory Pack-Box of 4)
- 505535—6" Sander Belt—Medium
- 505521—Medium (Factory Pack-Box of 4)
- 505536—6" Sander Belt—Coarse
- 505522—Coarse (Factory Pack-Box of 4)



### Safety Switch-Outlet Box

Guard your power tools against unauthorized use with your own padlock. Locks toggle switch in "off" position. Box also has handy outlet for lamp or other tools.

- 505556—Safety Switch-Outlet Box

### Safety Goggles

Large ventilated goggles permit wide field of vision, completely protect your eyes against dust and abrasive particles. Snug, comfortable fit even over glasses.

- 505557—Safety Goggles

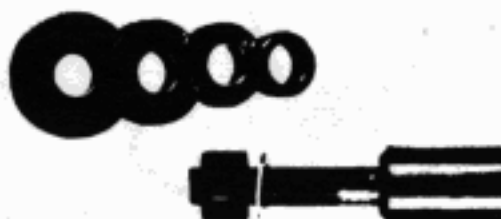

### Three-lip Shaper

A wide variety of three-lip shaper cutters for cutting molding, decorative edges, cupboard lips, etc. Cutters (see next box) are mounted on a 1/2" arbor or shaper adapter. A set of shaper collars is useful in controlling the depth of a cut when molding a curved surface; set of four range from 2 1/2" to 1 1/2" outside diameter.

- 505505—1/2" Universal Arbor (shaper adapter)
- 505604—Shaper Collar Set

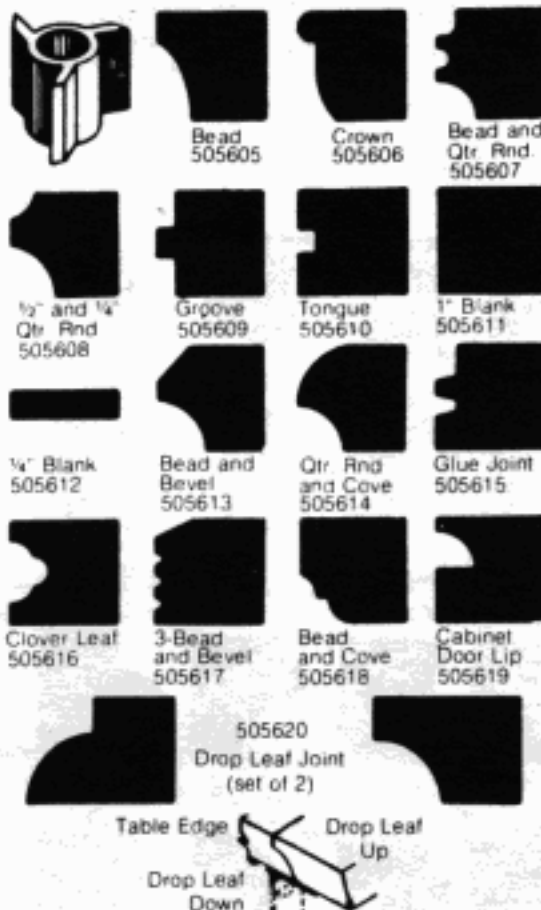

### Shaper Cutters

Three-lip shaper cutters used singly or in combination shape virtually any desired stock or special molding. Design your own decorative and functional edges on straight or curved pieces of wood. (No. 505620, a matched set of two cutters for cutting professional drop-leaf table joints.)

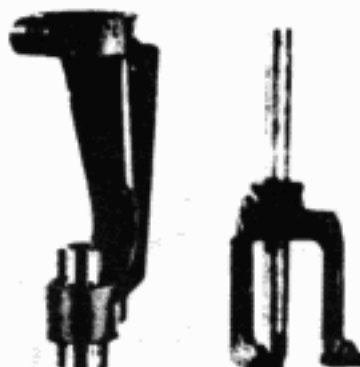

### Mortising Attachment

Guides chisel and bit in cutting clean, accurate square holes in soft and hard wood. Rugged, precision-machined cast iron with steel sleeve.

- 505623—Mortising Attachment

### Mortising Hold-Down

Prevents lifting of mortised workpiece when chisel and bit are withdrawn. Locks quickly on Shopsmith fence and is widely adaptable as a jig for other operations.

- 505624—Mortising Hold-down



### Mortising Bit/Chisel Sets

High quality, precision sets; bit drills out center as chisel cuts out corners of square holes. For use on Shopsmith with mortising attachment and hold-down to produce sharp, clean square holes and mortises.

- 505593—1/4" Mortise Bit/Chisel Set
- 505596—3/16" Mortise Bit/Chisel Set
- 505594—3/8" Mortise Bit/Chisel Set
- 505595—1/2" Mortise Bit/Chisel Set

### Individual Bits and Individual Chisels

Must be specially ordered.

- 505685—1/4" Mortising Chisel
- 505691—3/16" Mortising Chisel
- 505686—3/8" Mortising Chisel
- 505687—1/2" Mortising Chisel
- 505688—1/4" Mortising Bit
- 505692—3/16" Mortising Bit
- 505689—3/8" Mortising Bit
- 505690—1/2" Mortising Bit



### 6" Dado Blade set

Precision dado assembly for grooving, rabbeting, tenoning, etc. includes two special 6" hard chrome plated blades and four precision ground chippers. Width of cut up to 1 3/16" is adjusted by changing number and thickness of chippers mounted between blades. Mounts on all 3/8" universal arbors. With Shopsmith, use "Table Insert-Dado" (505621)

- 505548—Dado Blade Set



### Auger Bits

Best type of bits for power drilling in soft and hard woods—particularly large diameter holes. Require minimum pressure, fast chip removal. "Power point" pilot insures straight, smooth hole. Finest tempered tool steel. Set includes 5 bits; 1/4", 3/8", 1/2", 5/8", and 3/4"

- 505585—Auger Bit Set

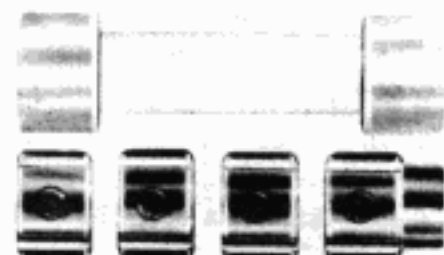

### ADD-A-TOOL Coupling Kit

Complete set of driving hubs and flexible coupling to connect all Shopsmith ADD-A-TOOL accessories. Hubs fit auxiliary drive spindles and accessory drive shafts; coupling is pressure molded of practically unbreakable Zytel.

- 505631—Coupling Kit

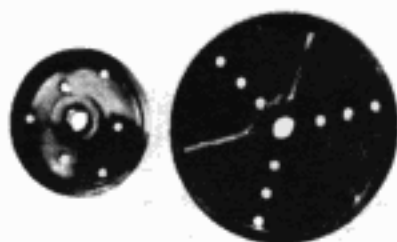

### Face Plates

Pressure cast from high density ductile aluminum, precision machined for turning bowls, lamp bases and other workpieces which cannot be turned between centers. Use 3 3/4" face plate for work from 4" to 8" in diameter and the 6" face plate for work from 7" to 15".

505590—3 3/4" Face Plate

505591—6" Face Plate

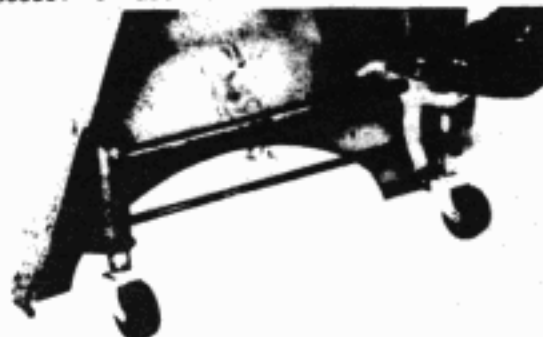

### Retractable Casters

Make movement and storage of Shopsmith and other tools quick and easy. A touch of the foot and the tool rises 1/4" off the floor, ready to roll; another touch and the bench settles solidly on the floor. Complete set quickly and easily installed.

505592—Retractable Casters (Mark V)

505500—Retractable Casters (Mark VII)



### Shaper & Drum Sander Fence

Used with three-lip shaper cutters or drum sander for precise shaping or finishing of straight edges. Exclusive infeed fence screw adjustment indicates each 1/64" of infeed adjustment. Should be used with Table Insert—Shaper & Drum Sander (505509). For Mark V and Mark VII.

505508—Shaper & Drum Sander Fence



### Table Inserts

All Shopsmith table inserts are pressure cast aluminum alloy, heavily ribbed for strength. Coined to insure flush fit with precision machined table surface.

#### Table Insert—Dado

Has 1" slot for dado blades.

505621—Table Insert, Dado

#### Table Insert—Molding

Specially designed for use with Shopsmith Molder in all molding operations.

505622—Table Insert—Molding

#### Table Insert—Shaper & Drum Sander

With fulcrum pins removed, used for the drum sander or beneath Shaper Fence to accommodate cutters, providing proper support for work. With fulcrum pins in place, used to guide workpiece when shaping or sanding curved surfaces.

505509—Table Insert, Shaper & Drum Sander



### Shopsmith Molder

Deluxe model, the finest available... a practical, easy-to-use tool that adds a plainly professional touch to almost any project. Shape table edges, cabinet door lips, sash molding, glue edges quickly and easily. Create virtually unlimited standard or original molding designs. Solid steel precision head accepts three-blade sets of molding knives automatically aligned and positively locked by ball and set screw. Mounts on 3/8" spindle or 1/2" universal arbor. With Shopsmith, use "Table Insert-Molder" (505622). Knife sets sold separately—see complete selection available.

505553—Magna Molder (deluxe model)

Molder comes complete with 12-page "how-to" booklet useful to any woodworker. It is available separately for 50¢; request Bulletin 503599.



Clover Leaf  
505560

Three-Bead  
505561

Ogee  
505569

Base Mold  
505563



3/16" and 3/8"  
Qtr. Rnd. and  
1/4" Bead  
505564

1/4" Cove  
505565

3/16" Cove  
and Qtr. Rnd.  
505566

Flute and  
Qtr. Rnd.  
505567



Cupboard  
Door Lip  
505568

Flute and  
Cove  
505562

1/4" and 1/2"  
Quarter Round  
505570

Wedge  
Groove  
505571



Wedge  
Tongue  
505572

1" Flute  
505573

45° Vee  
505574

Glue Joint  
505575



Cabinet  
Door Lip  
505576

Blank  
505577

### Shopsmith Molding Knife Sets

One or a combination of these superior quality, hardened steel knives will cut virtually any desired contour on straight or circular edges. Three matched knives per set.



### Miter Gauge Safety Grip

An exclusive Shopsmith safety feature. Just grasp the pistol grip firmly and it clamps the workpiece to the miter gauge and on the table. Your hands are safely away from the blade, accuracy is assured. Eliminates the normal tendency of workpieces to "creep" on a miter cut. Equally useful for bevel sanding and many other operations where firm, positive control of the workpiece is essential. Attaches to miter gauge quickly and easily.

505625—Miter Gauge Safety Grip

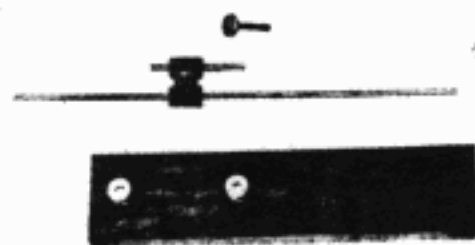

### Miter Gauge Stop Rod

Serves as jig for cross-cutting several workpieces to same length. Fits holes in Shopsmith miter gauge. Adjusts instantly to lengths up to 18"; can be used on either side of miter gauge.

505629—Miter Gauge Stop Rod

### Miter Gauge Extension

Hardwood extension equipped with knurled nut studs for quick mounting on Shopsmith miter gauge. Provides extra large miter gauge face for better, more accurate control of large workpieces.

505630—Miter Gauge Extension



### Sawdust Vacuum Bag

Cloth type—re-usable, durable porous weave cloth bag. Traps most sawdust and chips. Wide end opening for easy emptying.

505673—Sawdust Vacuum Bags—Cloth type (Mark VII)

### Sawdust Vacuum Bags—Disposable Type

Top quality, high porosity paper. Chemically treated.

505674—Sawdust Vacuum Bags—Disposable type (Mark VII) (pkg. of 3)

### Sawdust Vacuum Extension Hose—5 Foot

Heavy duty, industrial quality hose and coupling. Makes it easy to clean up every part of the workshop.

505675—Sawdust Vacuum Extension Hose—5-foot (Mark VII)

### Utility Nozzle

For Mark VII Sawdust Vacuum. Durable Plastic Popular Shape.

505677—Utility Nozzle

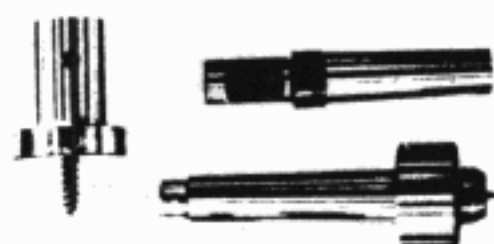

### Screw Center

For turning small diameter workpieces from 1" to 4" long without using the tailstock center. Replaceable wood screw is used to hold work on center.

505601—Screw Center

### Tailstock Chuck Arbor

Has #2 Morse taper, secures Jacobs chuck and drill on tailstock for drilling holes in workpieces mounted on driven spindle.

505603—Tailstock Chuck Arbor

### Live Center

Tailstock live center has precision ball-bearing tip to prevent burning of workpiece. Also useful for metal spinning operation. Fits any #2 Morse taper tailstock.

505602—Live Center

## A Safe Shop

SHOPSMITH M5 has the highest safety standards ever built into a home power tool; but SHOPSMITH is still a machine: it cannot think for you. Your comfort and personal safety depend as much on the care and thought you exercise as on SHOPSMITH'S built-in safety.

**Avoid standing in line with any cutting or abrading tool.**

Never rush a job. Correct tool speed is important, but rushing the job at even the right speed is poor craftsmanship.

**Wear safety goggles on all abrading and grinding operations.**

Do not wear rings, wrist watches or other jewelry when working in the shop. Take off your tie, keep sleeves buttoned tight around the wrist or rolled well above the elbow.

**No operation is good shop procedure if it brings your fingers too close to the cutting tool. Use a push stick or hold downs.**

Be sure that all machine locks are secure before turning on the machine. Double check when going from horizontal to vertical position.

**Keep your shop clean. Sawdust and oil on the floor are dangerous to life and limb and to the shop itself.**

Never reach over a machine for a tool. Arrange your shop and workbench so that accessories and other tools are behind you.

**Never make any adjustment on any power tool while it is in motion.**

Always provide maximum support for the work.

**Make periodic accuracy checks.**

Never remove a cutoff from the saw table while the blade is in motion.

**When sawing, keep blade projection just high enough to do the job—avoid the extremes.**

Keep cutting tools sharp.

**Never use the rip fence as a stop for cutting off duplicate pieces.**

When ripping, feed with the thumb; keep fingers hooked over the fence.

**Never operate any tool in excess of maximum recommended speed.**

Never cut freehand on the table saw. When cross-cutting, use the miter gauge—when ripping, use the rip fence.

Be sure that inserts are flush with the top of the table. Any unevenness should be immediately adjusted. SHOPSMITH M5 inserts are deliberately "bowed" during manufacture to assure flushness with table surface. When inserting, tighten front screw first and then tighten rear screw until insert is flush.

---

## Maintenance and Lubrication

**TUBULAR WAYS**—Hard chrome plating requires an occasional cleaning with paint thinners followed by an application of paste wax rubbed to a polish. Be sure to protect tubes during any abrading operation. This same procedure should be followed with extension table tubes, tailstock tubes and table tubes.

**BENCH TUBES**—These are corrosion proofed with a coating of clear lacquer. Under normal conditions this should last indefinitely. If lacquer surface is damaged, it should be repaired before metal is affected. (Use clear metal lacquer.)

**QUILL**—Lock quill in maximum extended position. Apply light coat of grease (Magna Lube) to rack teeth. Place a few drops of oil on top surface of quill and run quill in and out several times to spread the oil.

**BEARINGS**—All spindle bearings are grease sealed and require no lubrication for the life of the machine.

**HEADREST LOCK HANDLE**—Place a light coating of vaseline or grease on the cam surface. Occasionally, place a drop of oil on the threads.

**RIP FENCE**—Apply a few drops of machine oil on the threads of the rip fence lock rod.

**UNPAINTED ALUMINUM SURFACES**—An occasional application of paste wax, rubbed to a polish will not only protect the metal but will also allow work to slide more smoothly.

**PAINTED SURFACES**—To keep machine clean and looking new, apply an occasional coat of paste wax.

**ACCESSORIES**—All exposed iron or steel parts should be occasionally treated with RUST PREVENTIVE SPRAY (#12 049). Do not use RUST PREVENTIVE SPRAY on any chrome-treated parts.



# MAGNA

## POWER TOOL CORPORATION

SHOPSMITH\*\*

MAGNA\*\*

SPEEDIAL\*\*

SPEED-DIAL\*\*

\*\*TRADEMARK



\*Reg. U. S. Pat. Off.

## Operational Speeds

OPERATION		MATERIAL		SPECIAL SETTING	OPERATION		MATERIAL		SPECIAL SETTING
GENERAL SAWING		WOOD		R	D	Up to 1/4"		WOOD	S
HEAVY RIPPING		WOOD		O		1/4" - 1/2"			P
DADOING— MAGNA DADO		WOOD		MAGNA DADO		1/2" - 3/4"			M
DADOING— 6" DADO ASSY.		WOOD		R		3/4" - 1"			K
SAWING (SPECIAL BLADE)		PLASTICS		L		Over One Inch			SLOW
MOLDING		WOOD		R	R	Up to 1/8"		SOFT METAL	FAST
JOINTING		WOOD		R		1/8" - 1/4"			W
DISC SANDING	W O O D	COARSE PAPER		E		1/4" - 3/8"			S
		MEDIUM PAPER		DISC SAND		3/8" - 1/2"			O
		FINE PAPER		K		1/2" - 5/8"			K
		PLASTICS		F	5/8" - 3/4"			I	
		METAL		K	L	Up to 1/16"		MILD STEEL	FAST
DRUM SANDING		WOOD AND PLASTICS		K		1/16" - 1/8"			U
ROUTING		WOOD		ROUT-SHAPE		1/8" - 1/4"			L
SHAPING						1/4" - 3/8"			G
CARVING						3/8" - 1/2"			B
					Up to 1/8"			FAST	
MORTISING		SOFT WOOD		Q	G	1/8" - 1/4"		PLASTICS HARD RUBBER	S
		HARD WOOD		L		1/4" - 3/8"			L
WIRE BRUSHING	COARSE	METAL		D		3/8" - 1/2"			G
		WOOD (SCULPTURED EFFECTS)		L		1/2" - 5/8"			F
		METAL		Q		5/8" - 3/4"			A
BUFFING		HARD METAL		U	L	Up to 2"		ROUGHING	C
		SOFT METAL		S		2" - 4"		SHAPING	N
		PLASTICS		M				FINISHING	T
		HARD METAL		U				W	ROUGHING
POLISHING (LAMBSWOOL)		SOFT METAL		S		SHAPING			M
		PLASTICS		Q	FINISHING		Q		
JIG SAWING SABER SAWING		HARD METAL, BONE, PLASTICS		A	O	ROUGHING			SLOW
		HARD WOOD, SOFT METAL		JIG SAW		SHAPING			J
		SOFT WOOD, PLYWOOD, PRESSED WOOD		L		FINISHING		M	
JIG-SAW FILING, SANDING		SOFT METAL		S L O W		D	ROUGHING		SLOW
		HARD METAL					SHAPING		F
		WOOD			FINISHING		J		
		PLASTICS			ROUGHING		SLOW		
CUTTING WITH ABRASIVE CUT-OFF WHEEL		HARD METAL SOFT METAL PLASTICS		FOLLOW INSTRUCTIONS ON WHEEL OR PACKAGE	U		ROUGHING		SLOW
GRINDING		METAL				SHAPING		C	
POWER HONING		TOOL SHARPENING				FINISHING		D	
PLUG CUTTING		WOOD		Q		R	ROUGHING		SLOW
DRILLING WITH TUBE		GLASS		SLOW			SHAPING		G
					FINISHING		P		
					N		Up to 3"		PLASTICS
							Over 3"		ROUGHING
								SHAPING	P
								FINISHING	S
								ROUGHING	D
					G			SHAPING	F
								FINISHING	I
						UP TO 2" WITH CARBIDE TIPPED TOOLS		ROUGHING	SLOW
						NON-FERROUS METAL		SHAPING	G
								FINISHING	P